

GLEASON NO. 515 HYPOID TESTER

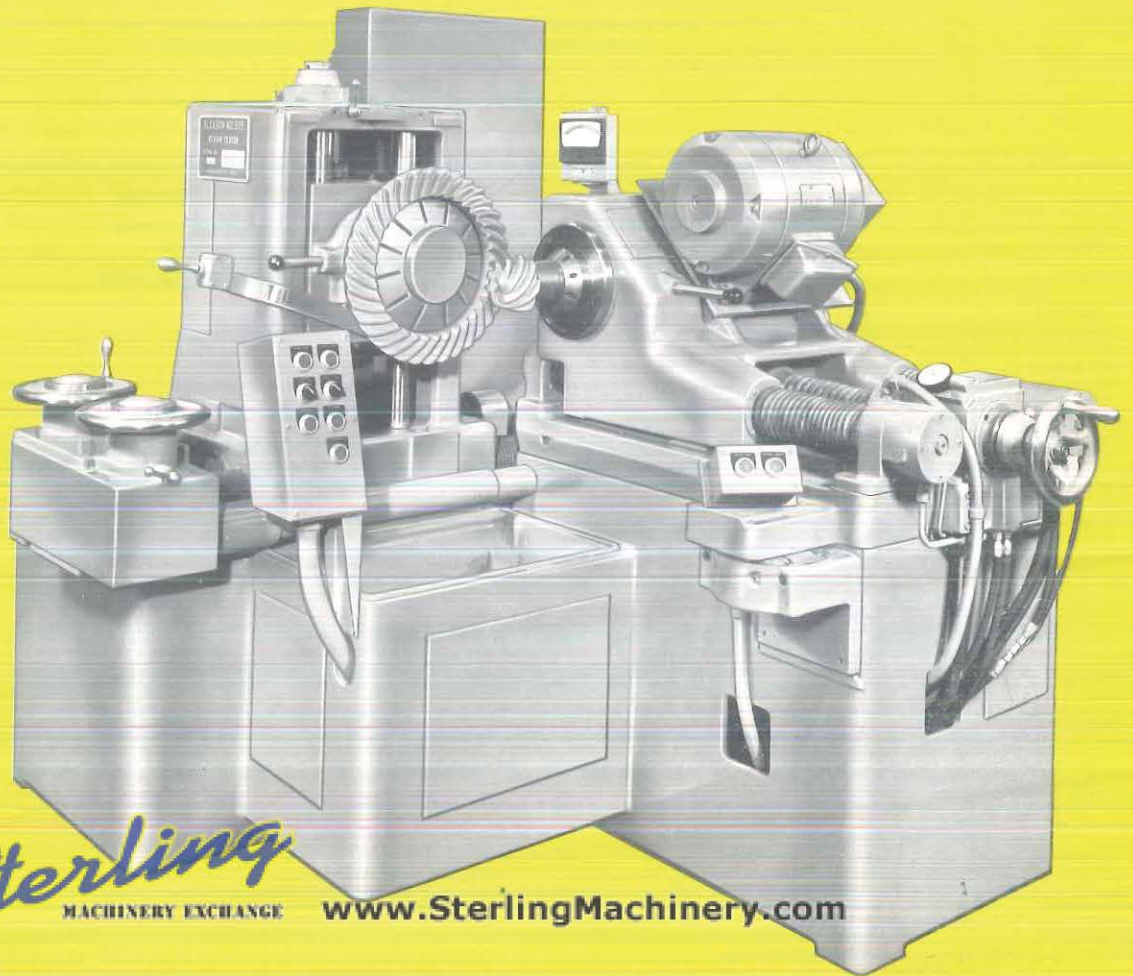

Sterling
MACHINERY EXCHANGE

www.SterlingMachinery.com

GLEASON No. 515 HYPOID TESTER

with new Swing Pinion Cone Adjustment for more precise testing of truck, bus and tractor main drive spiral bevel and hypoid gears operating at 90° shaft angle.

The No. 515 Hypoid Tester handles gears up to 24" in diameter and is invaluable for testing gears and pinions together under power, simulating actual operating conditions at all stages of bevel and hypoid gear manufacture.

SOFT TESTING . . . It is used in close conjunction with the gear cutting machines during setup and prior to production. The first gear of a lot is checked on the tester for tooth bearing (contact), tooth size, eccentricity, and smoothness and quietness of operation. The necessary corrections are made on the cutting machines. During production the No. 515 Hypoid Tester is used for making periodic checks of gear quality to assure uniformity of product.

MATCHING . . . After hardening, the No. 515 Tester is used to match gears and pinions in sets prior to lapping.

FINAL TESTING . . . After lapping, the No. 515 Tester is employed for a final test of the gear and pinion to assure that they will operate satisfactorily in the assembled drive axle. This procedure eliminates the necessity of axle disassembly for correction. This tester can also be arranged to run at drive spindle speeds from 200 to 2000 RPM, in order to test the operating characteristics of the gears at actual vehicle speeds. In addition, a slow roll check at variable pinion speeds up to 50 RPM may be used to determine variations in tooth size, eccentricity, tooth spacing and composite error.

SPC TESTING . . . It has been found that truck, bus and tractor rear axle drive gears may be subject to small amounts of shaft angle deflection under vehicle operating conditions. The effect of such deflections can be simulated on the No. 515 Tester by introducing a small amount of swing into the test setup. This use of swing pinion cone (SPC) testing has proven most valuable in the initial development of new rear axle ratios and also in the final test of the hardened and lapped gears prior to assembly.

In order to check and control the tooth bearing, the following adjustments are made (see illustration left).

A. The pinion head is swung in a slight arc with its pivot point centered in the tooth mesh. This moves the contact along the gear tooth so the tooth bearing can be checked at either end of the tooth or at any intermediate position. This adjustment is made by handwheel 2 in Fig. 1.

B. The gear head is moved in the direction of the pinion axis, which moves the bearing up and down the tooth profile. This adjustment is made by handwheel 1 in Fig. 1.

C. The pinion head is moved in the direction of the gear axis in order to maintain the desired backlash. This adjustment is made by the handwheel at 4 Fig. 3.

These accurate adjustments give unmatched flexibility, precise machine setups and insure uniform testing results.

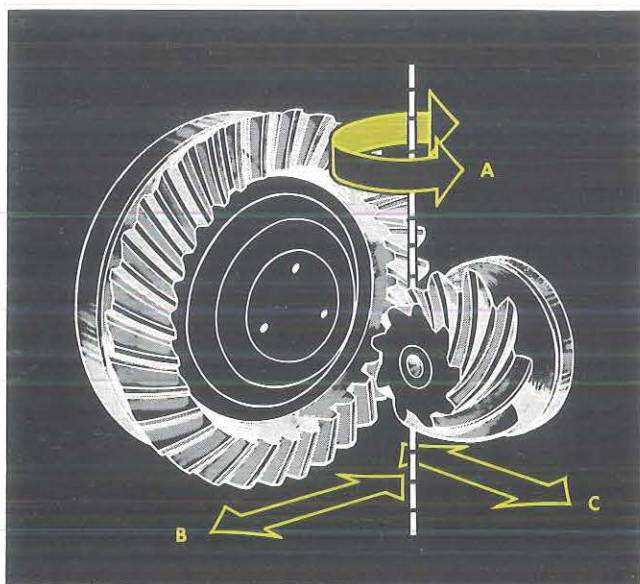

www.SterlingMachinery.com

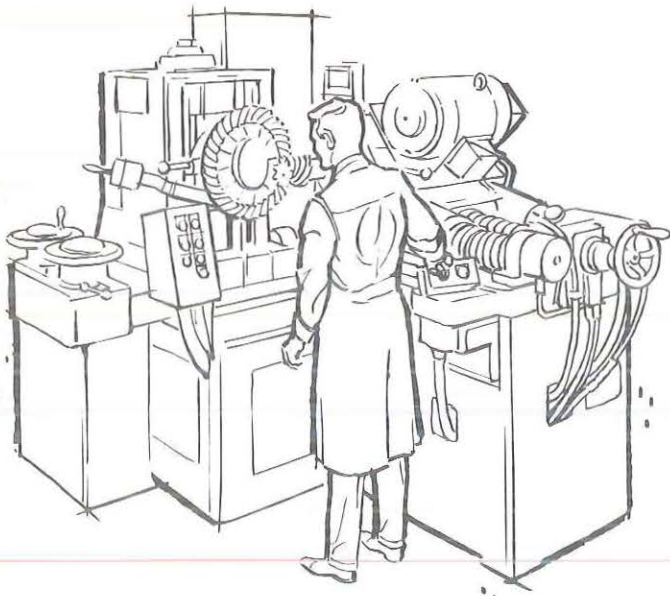

Fig. 1

ACCURATE, CONSTANT BACKLASH THROUGHOUT TESTING. An automatic backlash control mechanism provides the pre-selected amount of backlash. Once correct settings are made, the pinion is moved into metal-to-metal contact with the mating gear by operation of push button, 1 Fig. 3, and any size variation of the gears being tested is shown on dial indicator, 2 Fig. 3. Then the pinion head is automatically positioned by operation of push button, 1 Fig. 3, so that each pair of gears of a production lot is tested with the same backlash throughout the testing procedure as set on dial 3 Fig. 3, and read on dial indicator 2 Fig. 3. This insures more accurate manufacturing and uniformity of the gear pairs before actual assembly.

EASILY CONTROLLED BRAKE LOAD. A hand brake, 1 Fig. 2, on the brake spindle, is used in conjunction with the power running test. The amount of brake load is easily read on ammeter, 2 Fig. 2. Thus, the same amount of brake load can be applied to each pair of gears tested.

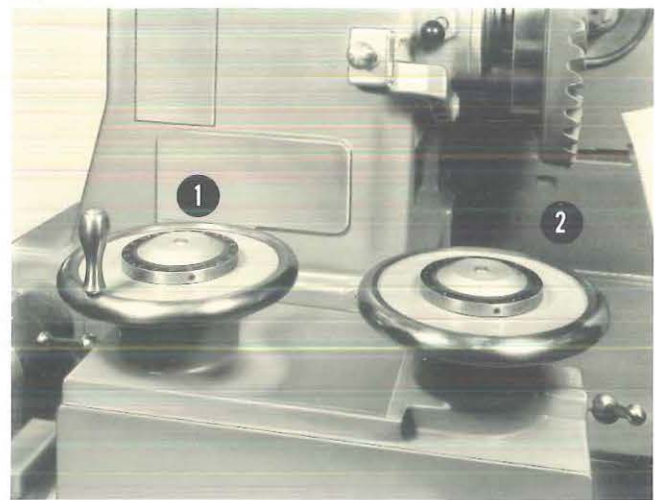

Fig. 2

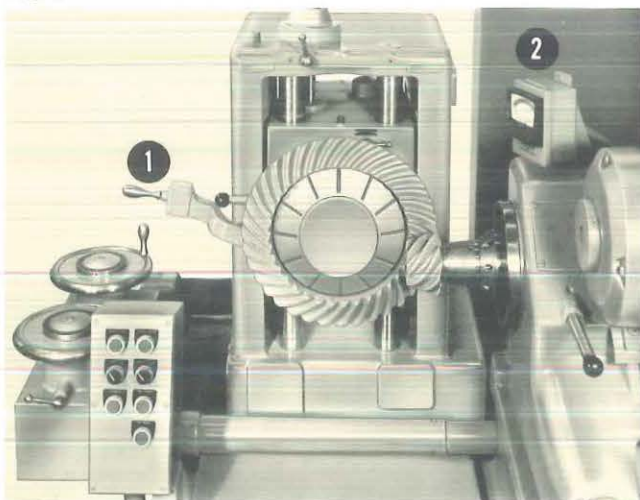
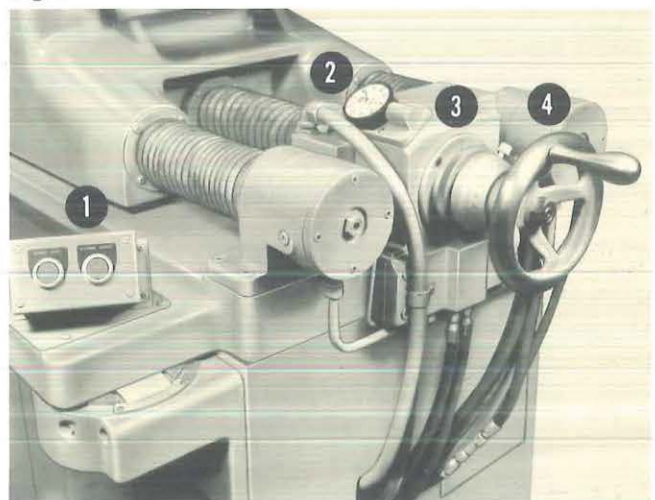

Fig. 3



SILENT, VIBRATION-FREE SPINDLES. High precision spindles are essential for accurately judging the running characteristics of gear sets. Both spindles of the No. 515 Tester are mounted on anti-friction bearings especially developed and built to Gleason specifications. Sufficient initial load is introduced in assembly of the spindle and bearings to eliminate all radial or axial deflection under ordinary operating conditions.

SPECIFICATIONS

No. 515 HYPOID TESTER (HYDRAULIC)

No. 515 HYPOID TESTER (MANUAL)

CAPACITY	ENGLISH	METRIC
Gear diameter (maximum).....	24"	609mm
Pinion diameter (maximum).....	12"	304mm
Offset of gear spindle above or below center of pinion spindle (maximum).....	6"	152mm

PINION SPINDLE

Diameter of taper hole at large end.....	3 ²⁹ / ₃₂ "
Taper per foot.....	3 ⁹ / ₆₄ "
Depth of taper.....	3"
Diameter of hole through spindle.....	3.740"

GEAR SPINDLE

Diameter of taper hole at large end.....	2 ¹⁹ / ₆₄ "
Taper per foot.....	1/2"
Depth of taper.....	3"
Diameter of hole through spindle.....	2.167"

ELECTRICAL EQUIPMENT	60 CYCLE	50 CYCLE
Main motor.....	5 H.P. 1800 R.P.M.	1500 R.P.M.
Hydraulic motor.....	3/4 H.P. 1800 R.P.M.	1500 R.P.M.

MISCELLANEOUS

Floor space.....	80" x 75"	203cm x 190cm
Height.....	72"	182cm
Net weight (approximate).....	10,000 lbs.	4536kg
Shipping weight (boxed for export, approximate).....	11,200 lbs.	5080kg
Size of case.....	90" x 85" x 86"	228cm x 216cm x 218cm

Note: These specifications are approximate. Where specific gear diameter approaches the maximum, submit prints for confirmation of machine capacity.

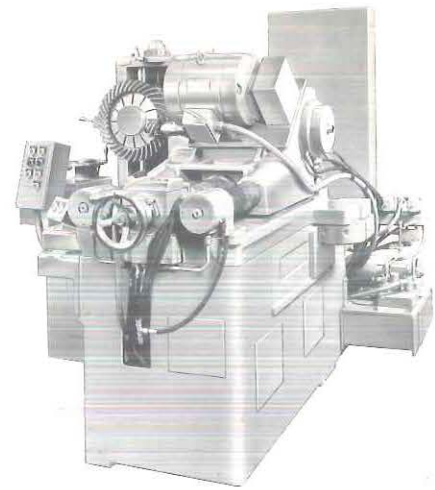

OPERATION. By means of handwheels and dials, the gear and pinion heads are set to the correct mounting positions with the gear head set vertically for offset (in the case of hypoids) and the pinion head set for swing.

For accuracy, convenience and exact duplication in production, the setup can be made with the aid of precision fixtures. Gear and pinion are then mounted in the arbors and chucked automatically by operation of a push button, 1 Fig. 3, which controls the double-acting hydraulic chucks. The hydraulic movement of the pinion head into and away from the normal testing position is controlled by the same push button.

For the power running test, the tooth contact can readily be observed by painting the teeth with marking compound and running the gears together for a few seconds with the desired brake load. For the rolling test, the gears are slowly rotated together at metal-to-metal contact to obtain a measure of the composite error.

No. 515 HYPOID TESTER (Hydraulic) (Code Word "ROLLA")

Standard Equipment

■ Arrangement for Swing Pinion Cone (S.P.C.) method of testing tooth bearing ■ Hydraulic power supply unit with accumulator ■ Hydraulic chucking both heads ■ Power movement of drive head in and out ■ Automatic preset backlash ■ Drive head spindle bore 3²⁹/₃₂" x 3⁹/₆₄" taper x 3" long ■ Brake head spindle bore 2¹⁹/₆₄" x 1/2" taper x 3" long ■ Complete electrical equipment for 3 phase, 50 or 60 cycle, alternating current.

Extra Equipment

■ Precision dial type indicator for pinion head ■ Ammeter for checking brake load for single speed A.C. motor only ■ Fixture for measuring mounting distance at front of pinion ■ Set-up bar assembly ■ 10 HP drive motor, AC-DC motor generator set and control equipment for variable drive spindle speeds from 200-2000 RPM including speed indicator in place of standard ■ Special drive head spindle bore 6" x 3/4" taper x 3" long in place of standard ■ Special brake head spindle bore 3²⁹/₃₂" x 3⁹/₆₄" taper x 3" long in place of standard ■ Two speed motor and control for 3 phase single voltage only for drive spindle speeds of 600 and 1200 RPM at 60 cycles in place of standard ■ Accumulator charging assembly.

No. 515 HYPOID TESTER (Manual) (Code Word "ROMAL")

Standard Equipment

■ Drive head spindle bore 3²⁹/₃₂" x 3⁹/₆₄" taper x 3" long ■ Brake head spindle bore 2¹⁹/₆₄" x 1/2" taper x 3" long ■ Complete electrical equipment for 3 phase, 50 or 60 cycle, alternating current.

Extra Equipment

■ Ammeter for checking brake load for single speed A.C. motor only ■ Fixture for measuring distance at front of pinion ■ Setup bar assembly ■ Arrangement for Swing Pinion Cone (S.P.C.) method of testing tooth bearing ■ Special drive head spindle bore 6" x 3/4" taper x 3" long in place of standard ■ Special brake head spindle bore 3²⁹/₃₂" x 3⁹/₆₄" taper x 3" long in place of standard ■ Two speed motor and control for 3 phase single voltage only for drive spindle speeds of 600 and 1200 RPM at 60 cycles in place of standard.

GLEASON WORKS

1000 University Avenue • Rochester 3, N.Y., U.S.A.

