

Image not found or type unknown



Ref. No.:

837-09111045

## Overview and Technical Data:

# TOYODA - FH 800 SX Horizontal Machining Center 4 Axis

[TOYODA](#)

TOYODA

Year of Build:

Apr 2007

## **Description:**

# **Used TOYODA FH 800 SX Horizontal Machining Center**

Operating Hours about 4000/year

Spindel Hours about 3000/year

## **Technical Data:**

- Control Fanuc 31i-A
- Travel distances
- X-way 1,250 mm
- Y-way 1.100 mm
- Z-way 1.050 mm
- Rapid traverse 48 m / min
- Tool holder HSK 100
- Table size 800 x 800 mm
- Number of pallets 2
- Max table load 1,300 kg.
- Spindle speed 8,000 rpm
- Spindle power 30 kW
- Spindle torque 600
- Number of tools 120 pcs.
- KNOLL high pressure system IKZ 70 bar
- Dimensions 7.450 x 4.200 x 4.100 mm.

## **Technical Data:**

## **Technical Data:**

Control:

[Series 31i](#)

Machine Hours:

36.000 hrs.

Spindle Hours:

27.000 hrs.

Spindle Speed:

8.000 rpm

Tool Capacity:

120 x

## **Travels:**

X-Axis:

1.250 mm

Y-Axis:

1.100mm

Z-Axis:

1.050 mm

### **Dimensions and Weight:**

Height:

4.100 mm

Width:

4.200 mm

Length:

7.450 mm

Weight:

28.000 kg

### **Buyer Information:**

Condition:

[Very good condition](#)

Availability:

[Sold](#)

Sold as:

[EXW \(Ex Works - Incoterm\)](#)

VAT:

[19 %](#)

Buyers Premium:

[16 %](#)

Location:

Germany

### **Images:**



1



# CONTROL SYSTEM

## JTEKT CORPORATION

MACH. No.	NS2222	TYPE	FH80
SUPPLY VOLTAGE	AC380 V	FREQ.	50
PHASE	3	FULL LOAD AMP.	82
I.C. OF CIRCUIT BREAKER			25
AMP. OF LARGEST LOAD			97
MAX. BREAKER SIZE			175
ELECTRICAL DIAGRAM No.			29-95517001
DATE	2007.4		

1-1, Asahimachi, Kariya, Aichi, Japan

FANUC Series 31i-MODEL A

1ST-POSITION

07025 N

ABSOLUT

X	40.000
Y <sub>H</sub>	59.800
Z <sub>H</sub>	-80.891
B	270.000

F

VST-ZAEHLER  
LAUFZEIT  
ZYKLUS-ZEIT  
BEDIENER-MELDUNG  
OPBS AUFNAHMETYP SPAENEFO  
T

MODAL

G01	G80	G15	F	8.029	M	3
G17	G90	G40.1	H	33	M	909
G98	G50	G25	D		M	
G22	G67	G160			HD. T	33
G95	G97	G13.1	S	2500	MX. T	: 0
G21	G52	G50.1	REPEAT	0/0		
G40	G64	G54.2				
G43	G69	G80.5				
S	2499	SLM	1			

MEH STRT MIN +++ 07:3

ABS REL ALLE ALARM MELDG. ARCHIV MLD

Emergency stop button (glowing green) and other control buttons (power, alarm, etc.)

OVERRIDE

Overhaul dial with markings for 0, 25, 50, 75, 100, 125, 150, 175, 200

RESET, HELP, POS, PROG, and other function buttons

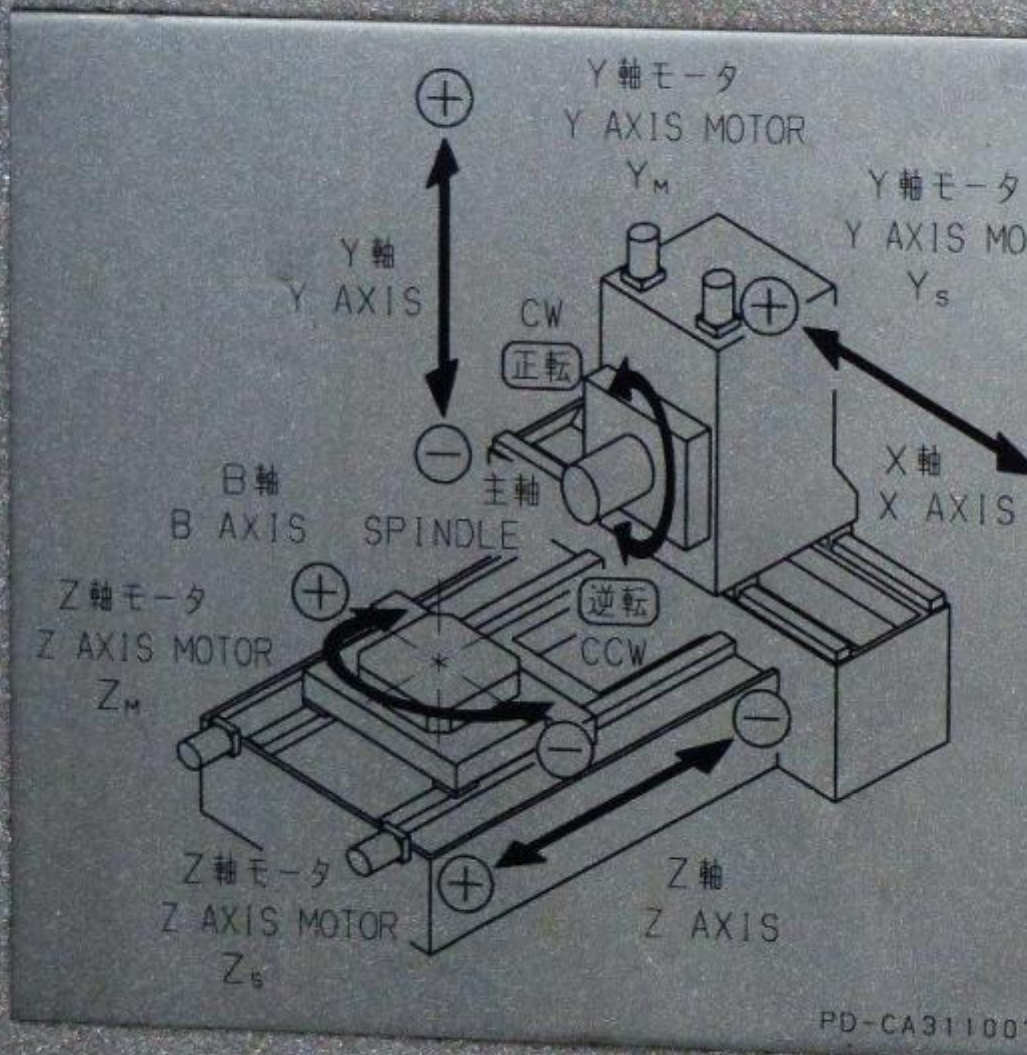



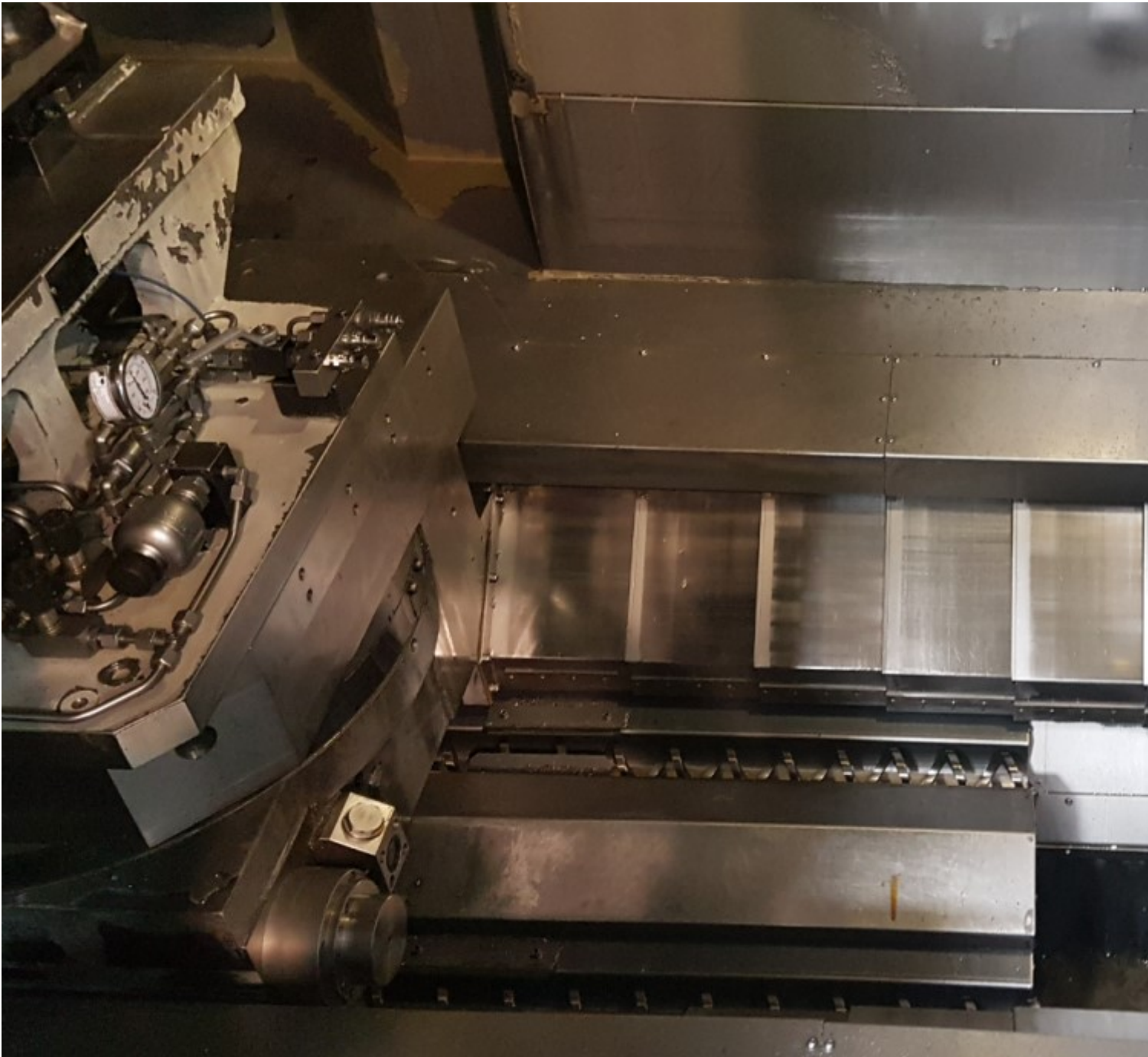







10





12







15







18

**Video:**



**Asset-Trade**  
Assessment & Sales of Used Assets



Asset-Trade

Assessment and Sale of Used Assets world wide

Am Sonnenhof 16

47800 Krefeld

Germany

Tel.: +49 2151 32500 33

Fax.: +49 2151 65 29 22

Email: [info@asset-trade.de](mailto:info@asset-trade.de)

Web.: <https://www.asset-trade.de/en>

Ref. No.:  
837-09111045

**Overview and Technical Data:**

**TOYODA - FH 800 SX Horizontal Machining Center 4 Axis**

**TOYODA**

# TOY

Year of Build:

Apr 2007

**Description:**

**Used TOYODA FH 800 SX Horizontal Machining Center**

Operating Hours about 4000/year

Spindel Hours about 3000/year

Technical Data:

- Control Fanuc 31i-A

- Travel distances
- X-way 1,250 mm
- Y-way 1.100 mm
- Z-way 1.050 mm
- Rapid traverse 48 m / min
- Tool holder HSK 100
- Table size 800 x 800 mm
- Number of pallets 2
- Max table load 1,300 kg.
- Spindle speed 8,000 rpm
- Spindle power 30 kW
- Spindle torque 600
- Number of tools 120 pcs.
- KNOLL high pressure system IKZ 70 bar
- Dimensions 7.450 x 4.200 x 4.100 mm.

## **Technical Data:**

## **Technical Data:**

Control:

[Series 31i](#)

Machine Hours:

36.000 hrs.

Spindle Hours:

27.000 hrs.

Spindle Speed:

8.000 rpm

Tool Capacity:

120 x

## **Travels:**

X-Axis:

1.250 mm

Y-Axis:

1.100mm

Z-Axis:

1.050 mm

## **Dimensions and Weight:**

Height:

4.100 mm

Width:

4.200 mm

Length:

7.450 mm

Weight:

28.000 kg

## **Buyer Information:**

Condition:

[Very good condition](#)

Availability:

[Sold](#)

Sold as:

[EXW \(Ex Works - Incoterm\)](#)

VAT:

[19 %](#)

Buyers Premium:

[16 %](#)

Location:

Germany

## **Images:**



1



# CONTROL SYSTEM

## JTEKT CORPORATION

MACH. No.	NS2222	TYPE	FH80
SUPPLY VOLTAGE	AC380 V	FREQ.	50
PHASE	3	FULL LOAD AMP.	82
I.C. OF CIRCUIT BREAKER			25
AMP. OF LARGEST LOAD			97
MAX. BREAKER SIZE			175
ELECTRICAL DIAGRAM No.			29-95517001
DATE	2007.4		

1-1, Asahimachi, Kariya, Aichi, Japan

FANUC Series 31i-MODEL A

1ST-POSITION

07025 N

ABSOLUT

X	40.000
Y <sub>H</sub>	59.800
Z <sub>H</sub>	-80.891
B	270.000

F

VST-ZAEHLER  
LAUFZEIT  
ZYKLUS-ZEIT  
BEDIENER-MELDUNG  
OPBS AUFNAHMETYP SPAENEFO  
T

MODAL

G01	G80	G15	F	8.029	M	3
G17	G90	G40.1	H	33	M	909
G98	G50	G25	D		M	
G22	G67	G160			HD. T	33
G95	G97	G13.1	S	2500	MX. T	: 0
G21	G52	G50.1	REPEAT	0/0		
G40	G64	G54.2				
G43	G69	G80.5				
S	2499	SLM	1			

MEH STRT MIN +++ 07:3

ABS REL ALLE ALARM MELDG. ARCHIV MLD

Emergency stop button (glowing green) and various function buttons (orange and red).

Row of navigation buttons including a left arrow and several square buttons.

OVERRIDE

Overriding speed dial with markings for 0, 50, 100, and 200.

Row of function buttons including RESET, HELP, POS, PROG, and others.

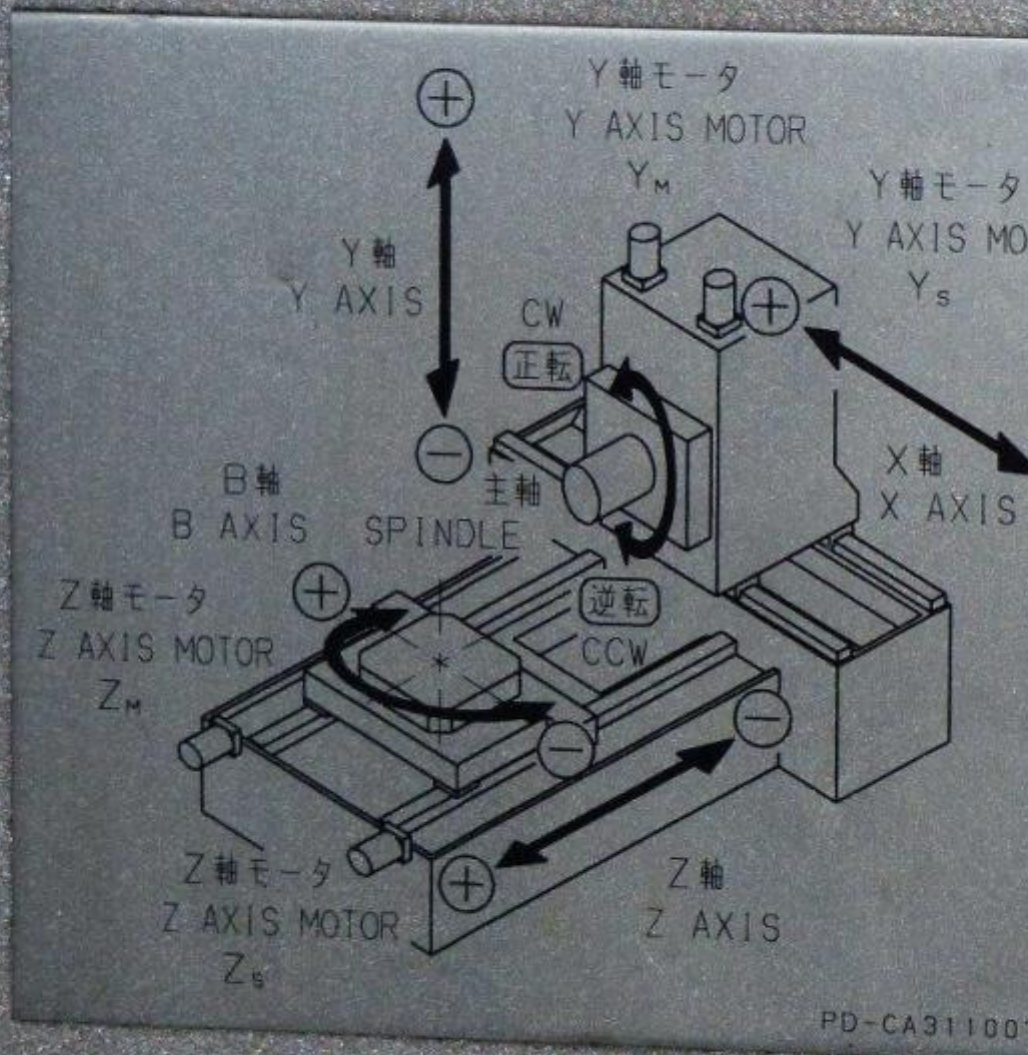



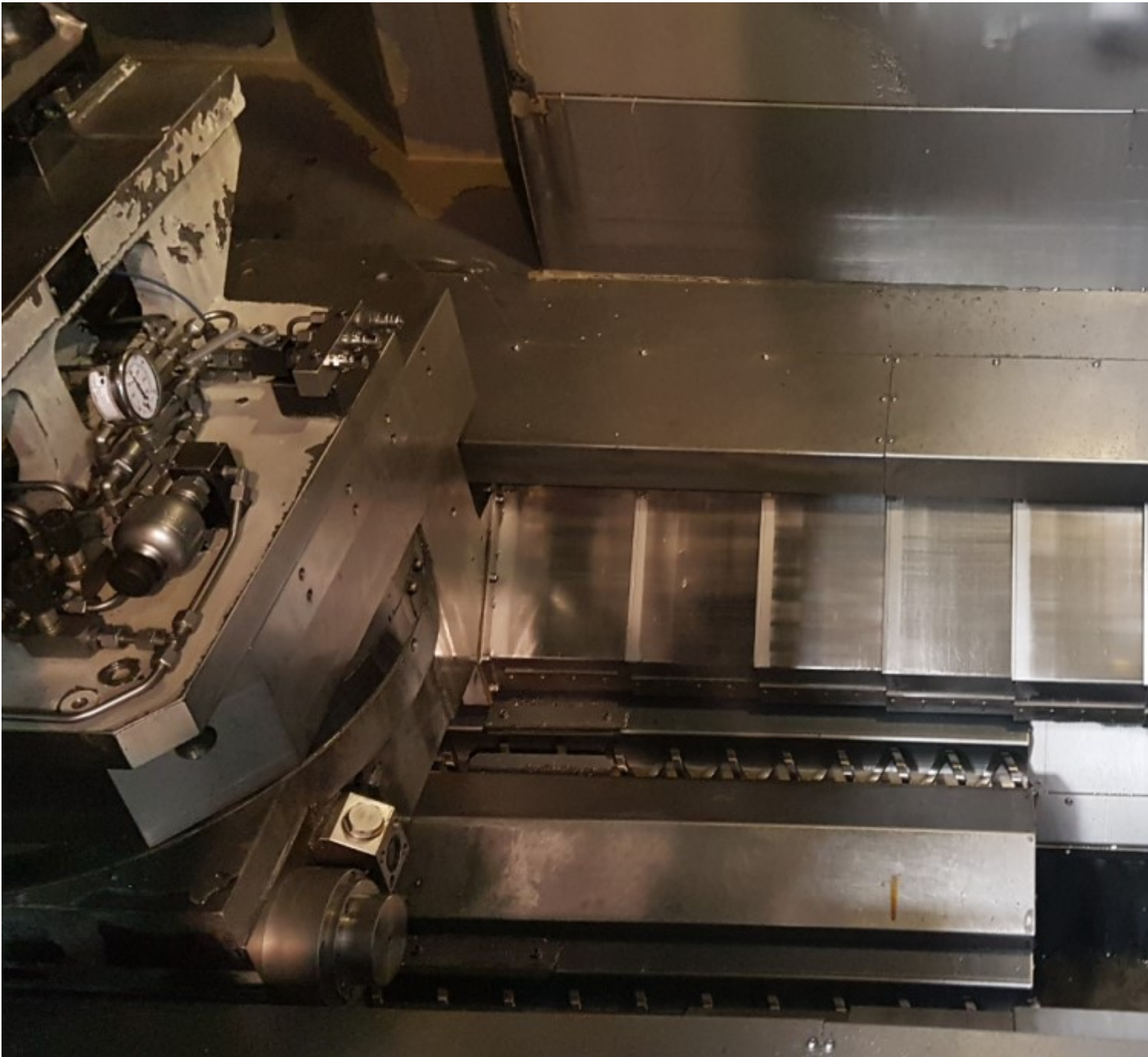







10





12







15







18

**Video:**



**Asset-Trade**  
Assessment & Sales of Used Assets



Asset-Trade

Assessment and Sale of Used Assets world wide

Am Sonnenhof 16

47800 Krefeld

Germany

Tel.: +49 2151 32500 33

Fax.: +49 2151 65 29 22

Email: [info@asset-trade.de](mailto:info@asset-trade.de)

Web.: <https://www.asset-trade.de/en>

Generated on 26.05.2026

© Copyright 2026 - [Asset-Trade](#)

Page