

Image not found or type unknown



Ref. No.:

1042 - 10121416

## Overview and Technical Data:

# MAZAK - MTV 515/40N new Spindel in 2017

[MAZAK](#)

Year of Build:

Mar 1999

## Description:

### Used MAZAK MTV 515 / 40N Vertical Milling Machine

New spindle bearing in 2017 !!!

CNC control Mazatrol 640 M

Technical specifications

- Travels X / Y / Z: 1050/510/560 mm
- Number of pallets 2x
- Max table weight 1500 KG
- Spindle speed 25 - 6,000 rpm 22KW
- ATC magazine: 30 (ISO 50)

- Synchronized tapping
- Tool measurement system
- chip conveyor
- High pressure coolant
- Spindel Trough coolant

Machine still under power until K51

## **Technical Data:**

## **Technical Data:**

Control:

[Mazatrol 640M](#)

Spindle Hours:

3.274 hrs.

Spindle Speed:

6.000 rpm

Tool Capacity:

30 x

## **Travels:**

X-Axis:

1.050 mm

Y-Axis:

510mm

Z-Axis:

560 mm

## **Dimensions and Weight:**

Weight:

9.000 kg

## **Buyer Information:**

Condition:

[Very good condition](#)

Availability:

[Sold](#)

Sold as:

[EXW \(Ex Works - Incoterm\)](#)

VAT:

[19 %](#)

Buyers Premium:

[16 %](#)

Location:

Germany

**Images:**



1





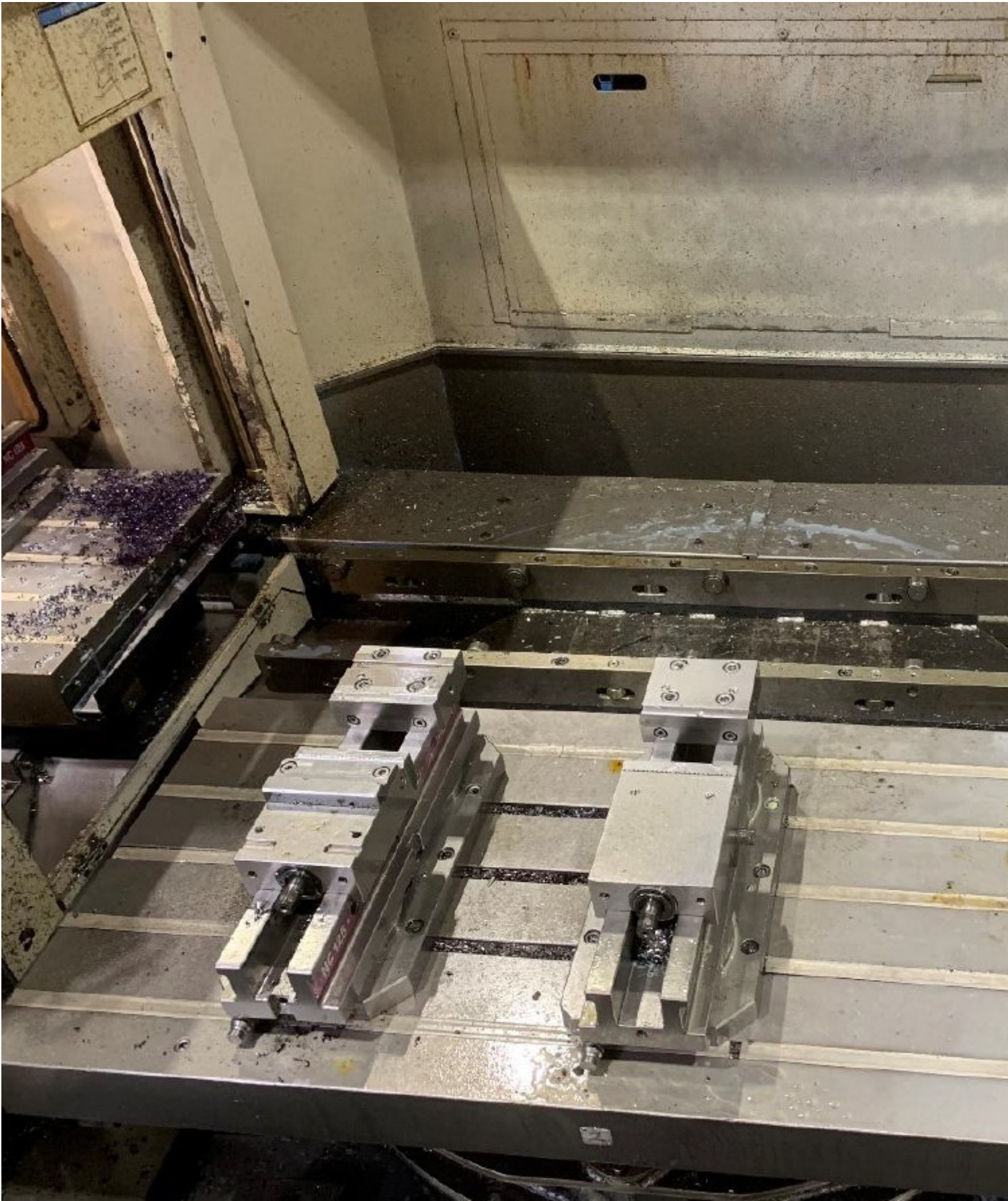











### PARTS LAYOUT

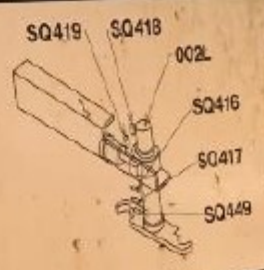



MAX.  
SPINDELDR

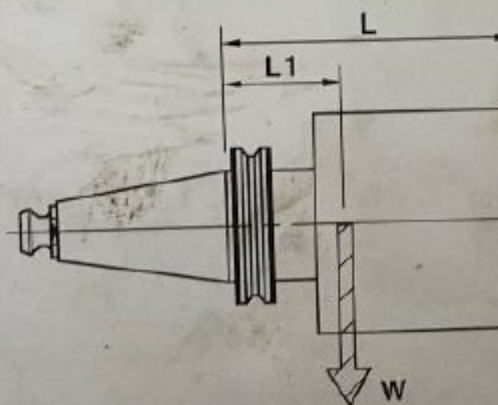

# ACHTUNG



Stets Hae  
vom Arbe  
fernhalten  
zum schw  
fuehren.

## SICHE

1. Beim V  
manuel
2. Bei Ins  
abscha
3. Bei We  
Sie sic  
am We
4. Stets V  
guter I

**MODEL** MTV 515 / 40N

**SER. NO.** 141292

**DATE** 1999.3

**WEIGHT** 8900 kg 19580 LBS



**YAMAZAKI MAZAK CORP.**

Oguchi-cho Aichi Pref., Japan

MADE IN JAPAN

イイ 33566156400

**MAZAK CONTROL BOX**

**MODEL** MTV 515 / 40N

**ASS. NO.** 333141292

**DATE** 99-03

**ELEMENTARY DIAGRAM** 00539101001

**MAIN CIRCUIT** 3AC 400 V50/60Hz

**CONTROL CIRCUIT** AC100V DC24V

**MAIN MOTOR** MAX. 92 A. 200V

**RATED CAPACITY** 42.9 KVA.



**YAMAZAKI MAZAK CORP.**

MADE IN JAPAN

イイ 34266233412



M 19



**DIAGNOSE (ANWENDER)**  
Ordner Fenster Hilfe

ALARM | ALARM HISTORY | PLC SIGNAL

Nr.                      ALARM NACHRICHT

**GESAMT ZEITEN**

GESAMT  
AUT. ABLA.  
AUT. ZERS.  
REI. ZERS.  
BETR. ZEIT

50%    100%    100%

DIAGNOSE VERSION	ALARM	ALARM HISTORY	PLC SIGNAL	WARTUNGS ANZEIGE	PLC	LAUFZEIT ANZEIGE
---------------------	-------	------------------	---------------	---------------------	-----	---------------------





Asset-Trade

Assessment and Sale of Used Assets world wide

Am Sonnenhof 16

47800 Krefeld

Germany

Tel.: +49 2151 32500 33

Fax.: +49 2151 65 29 22

Email: [info@asset-trade.de](mailto:info@asset-trade.de)

Web.: <https://www.asset-trade.de/en>

Ref. No.:

1042 - 10121416

**Overview and Technical Data:**

**MAZAK - MTV 515/40N new Spindel in 2017**

Year of Build:  
Mar 1999

**Description:**

**Used MAZAK MTV 515 / 40N Vertical Milling Machine**

New spindle bearing in 2017 !!!

CNC control Mazatrol 640 M

Technical specifications

- Travels X / Y / Z: 1050/510/560 mm
- Number of pallets 2x
- Max table weight 1500 KG
- Spindle speed 25 - 6,000 rpm 22KW
- ATC magazine: 30 (ISO 50)
- Synchronized tapping
- Tool measurement system
- chip conveyor
- High pressure coolant
- Spindel Trough coolant

Machine still under power until K51

**Technical Data:**

**Technical Data:**

Control:

## Mazatrol 640M

Spindle Hours:

3.274 hrs.

Spindle Speed:

6.000 rpm

Tool Capacity:

30 x

## **Travels:**

X-Axis:

1.050 mm

Y-Axis:

510mm

Z-Axis:

560 mm

## **Dimensions and Weight:**

Weight:

9.000 kg

## **Buyer Information:**

Condition:

Very good condition

Availability:

Sold

Sold as:

EXW (Ex Works - Incoterm)

VAT:

19 %

Buyers Premium:

16 %

Location:

Germany

## **Images:**



1

















### PARTS LAYOUT

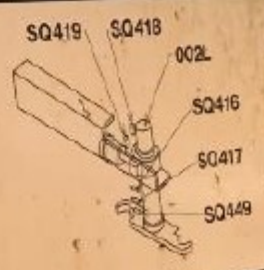



MAX.  
SPINDELDR

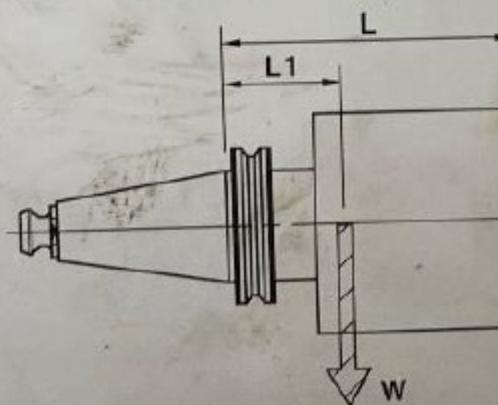

# ACHTUNG



Stets Hae  
vom Arbe  
fernhalten  
zum schw  
fuehren.

## SICHE

1. Beim V  
manuel
2. Bei Ins  
abscha
3. Bei We  
Sie sic  
am We
4. Stets V  
guter I

**MODEL** MTV 515 / 40N

**SER. NO.** 141292

**DATE** 1999.3

**WEIGHT** 8900 kg 19580 LBS



**YAMAZAKI MAZAK CORP.**

Oguchi-cho Aichi Pref., Japan

MADE IN JAPAN

イイ 33566156400

**MAZAK CONTROL BOX**

**MODEL** MTV 515 / 40N

**ASS. NO.** 333141292

**DATE** 99-03

**ELEMENTARY DIAGRAM** 00539101001

**MAIN CIRCUIT** 3AC 400 V50/60Hz

**CONTROL CIRCUIT** AC100V DC24V

**MAIN MOTOR** MAX. 92 A. 200V

**RATED CAPACITY** 42.9 KVA.



**YAMAZAKI MAZAK CORP.**

MADE IN JAPAN

イイ 34266233412



M 19



**DIAGNOSE (ANWENDER)**  
Ordner Fenster Hilfe

ALARM | ALARM HISTORY | PLC SIGNAL

Nr. ALARM NACHRICHT

**GESAMT ZEITEN**  
GESAMT  
AUT. ABLA.  
AUT. ZERS.  
REI. ZERS.  
BETR. ZEIT

50% 100% 100%

DIAGNOSE VERSION	ALARM	ALARM HISTORY	PLC SIGNAL	WARTUNGS ANZEIGE	PLC	LAUFZEIT ANZEIGE
---------------------	-------	------------------	---------------	---------------------	-----	---------------------





Asset-Trade

Assessment and Sale of Used Assets world wide

Am Sonnenhof 16

47800 Krefeld

Germany

Tel.: +49 2151 32500 33

Fax.: +49 2151 65 29 22

Email: [info@asset-trade.de](mailto:info@asset-trade.de)

Web.: <https://www.asset-trade.de/en>

Generated on 30.05.2026

© Copyright 2026 - [Asset-Trade](#)

Page