

**SP43  
EDM WIRE MACHINE  
PRE-INSTALL DOCUMENT**

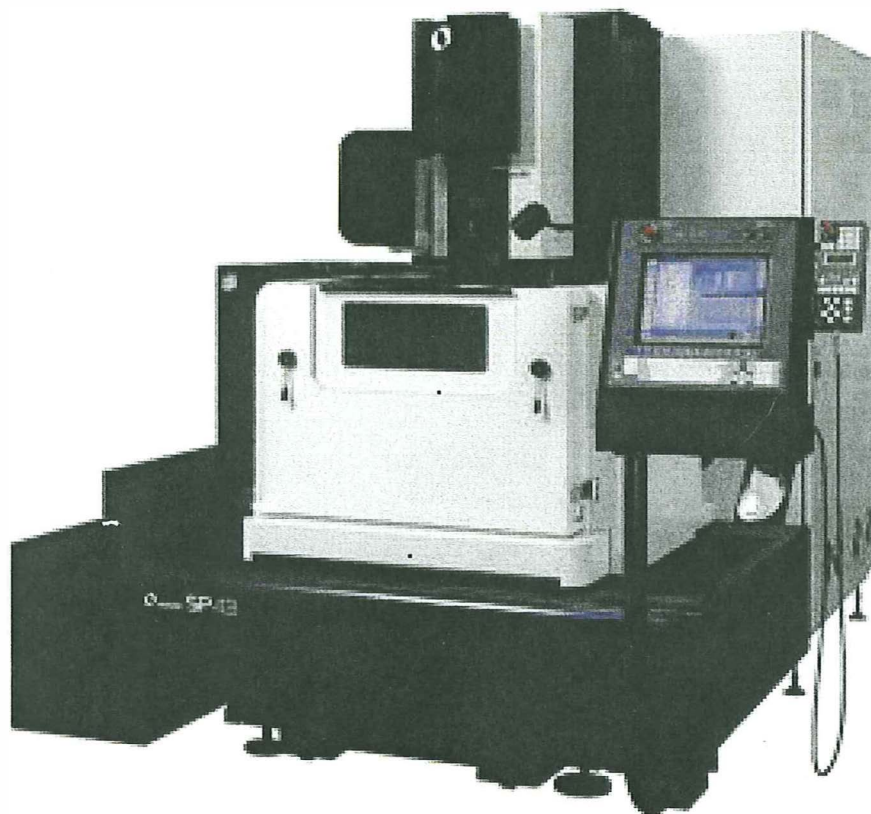

---

7680 Innovation Way  
Mason, Ohio 45040  
800-552-3288 / 513-573-7200  
Fax 513-573-7456  
<http://www.makino.com>

# SP43 SUPPLEMENTAL INFORMATION

## PRECAUTION ON INSTALLATION

- 1) The machine must be installed or relocated by only the qualified personnel designated by Makino.
- 2) The “Installation” manual covers the installation requirements and facilities necessary for machine installation. For the safety use of machine, prepare the facilities that satisfy completely the installation requirements.

## SP43 Environmental Requirements

Select an installation place while taking care of the following points:

- The machine must be placed on one concrete pad and not across a seam
- A place free from vibration and shock
- A light place free from dust
- A place not exposed to direct sun light
- A place of less temperature change
- The cooling fans are provided, one each at the machine, NC power supply unit, and dielectric fluid • air pressure supply unit. Therefore, the installation place should ensure the intake and exhaust air flow.
- Ensure sufficient service area by referring to the layout plans .
- Provide a space for easy workpiece mounting and dismounting.
- An easily accessible place to carry in and out the machine
- A place durable to the machine weight
- A place where the floor surface around the machine is applied with the anti-slip treatment.
- In order to prevent the radio wave interference, a shield room may be required, depending on the environment.
- Ensure the dielectric fluid disposal place since the dielectric fluid cannot be drained directly into a general drainage because it contains chips.

A drain port is provided on the rear of dielectric fluid • air pressure supply unit.

## INSTALLATION SPECIFICATIONS

Machine Dimensions		
Width X Depth X height	2180 x 2875 x 2250 mm	86" X 114" X 89"
Required Floor Space	3000 x 4100 mm	119" X 162"
Machine weight	3400 kg.	9110 lbs
Ambient temperature	10 ~35° C ± 1°	50 ~ 95°F ±2°
Optimum Temperature	20° C ± 1°	68°F ± 2°

Do not expose the machine to direct sunlight. Make sure that air conditioning vents are not blowing hot or cold air directly at the machine.

**Shipping** We recommend Air Ride Transportation. Machines are shipped FOB Port of Entry in two containers.

**Electrical** Specify either 230 or 460 volts, The SP43 requires 21 KVA input power with a ground of 10 ohms or less.

Example: 
$$\frac{\text{KVA} \times 1000}{1.73 \times \text{Voltage}} = \text{Amperage} \times 125\% = \text{Service Required}$$

**Air** Clean, dry compressed air of 70 psi. must be available

**Water** Ordinary drinking water can be piped directly into the dielectric reservoir. Dielectric Reservoir Capacity = 1000 liters = 264 gallons

**Environment** Choose an area free of dust and vibration. An isolated foundation may be necessary if excessive vibration is present. The machine should be located in an area free of high volumes of dust, away from polishing or grinding machines.

Best results are achieved when stable temperatures and humidity are maintained.

Vibration ..... 0.7 m/s<sup>2</sup> {0.07 G} or less

Relative humidity ..... 75% or less (no condensation)

Specifications may change without prior notice to incorporate improvements resulting from ongoing R&D programs. Cover

## SP43 SUPPLEMENTAL INFORMATION

### SP43 Air Requirements

The air pressure is required for the machine to operate. The machine stops if the air pressure lowers below 0.3MPa during operation. Prepare stable air pressure source.

Prepare the following:

#### Air pressure source

Pressure : 0.6MPa or more  
Flow rate : 100L/min (atmospheric pressure) or more

#### Air hose

Inside dia.: 8mm minimum

An air supply coupler is attached to the machine as a standard accessory. Connect the prepared air hose to this coupler.

Confirm with the pressure gauge that the air pressure is the specified value. If out of the specified value, adjust it with the regulator.

**Caution:** If a compressor in the factory is stopped once, then it is started abruptly, the auto drain may be kept open, causing the pressure not to rise up to the specified value. In this case, reconnect the coupler.

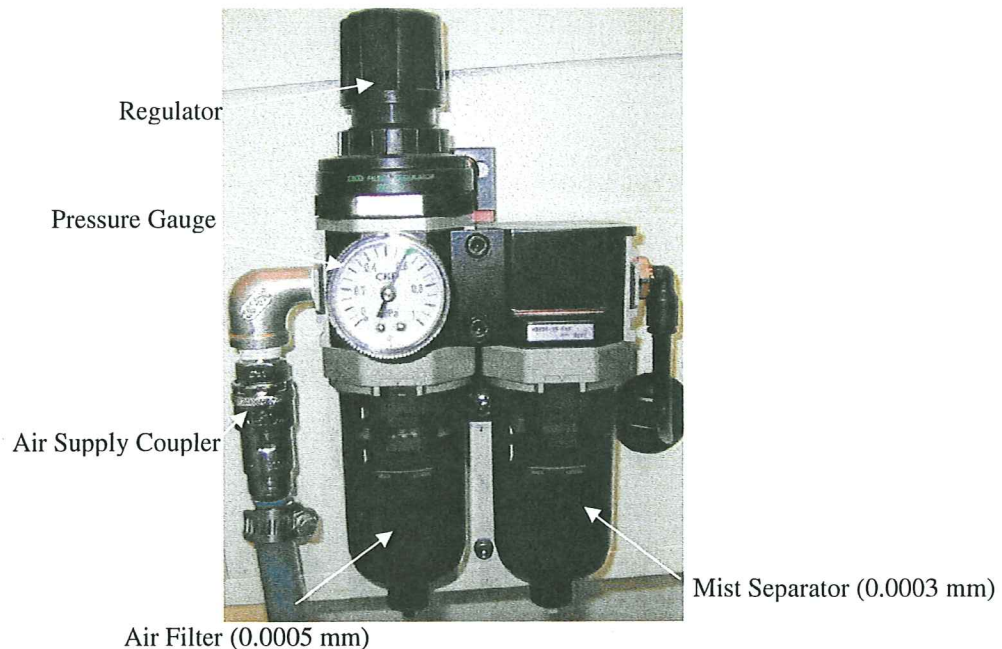

Air Filter (0.0005 mm)

Mist Separator (0.0003 mm)

Air Supply Piping Facility

## MACHINE PHOTOGRAPHS



View of DI Tank



View of Electrical Cabinet

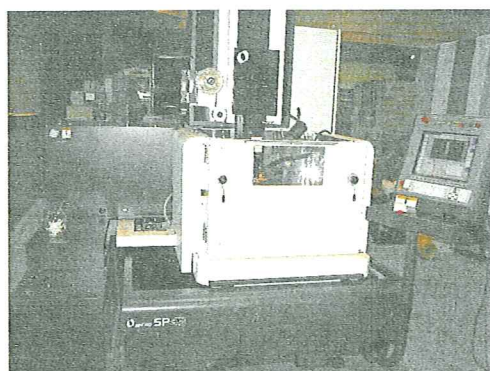

Front View of Machine

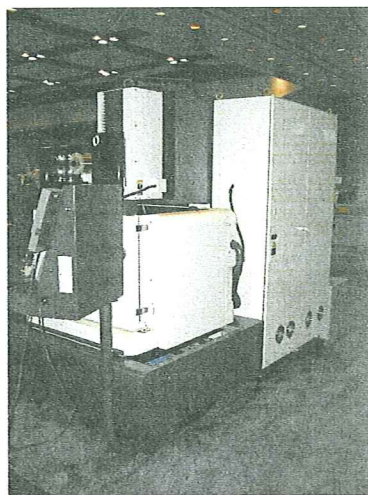

Side View of machine

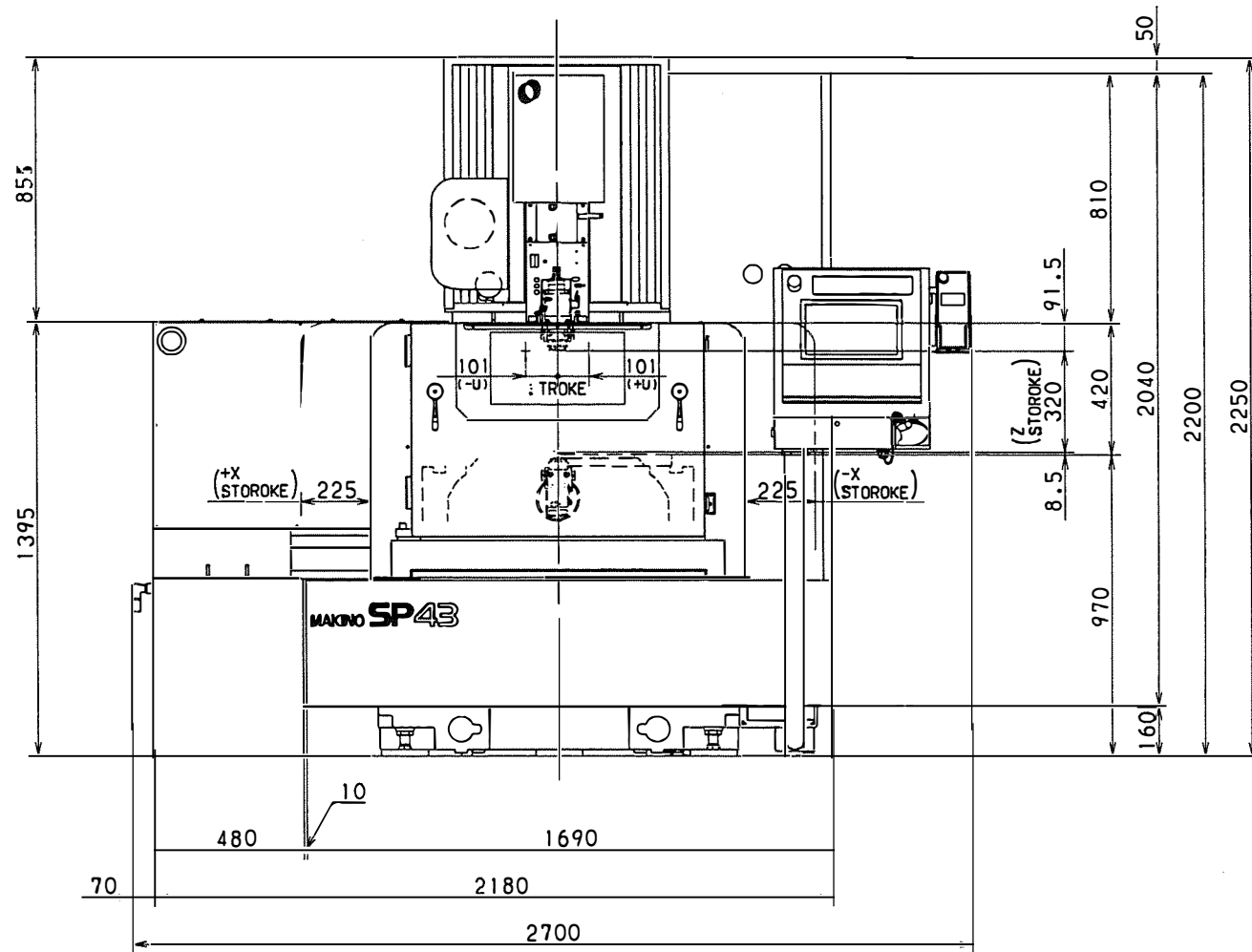

GENERAL VIEW SP43 (V\* 2)  
 SLIM TYPE  
 SPECIAL COVER FOR MT  
 Z0EC10M451-00 (1/4)

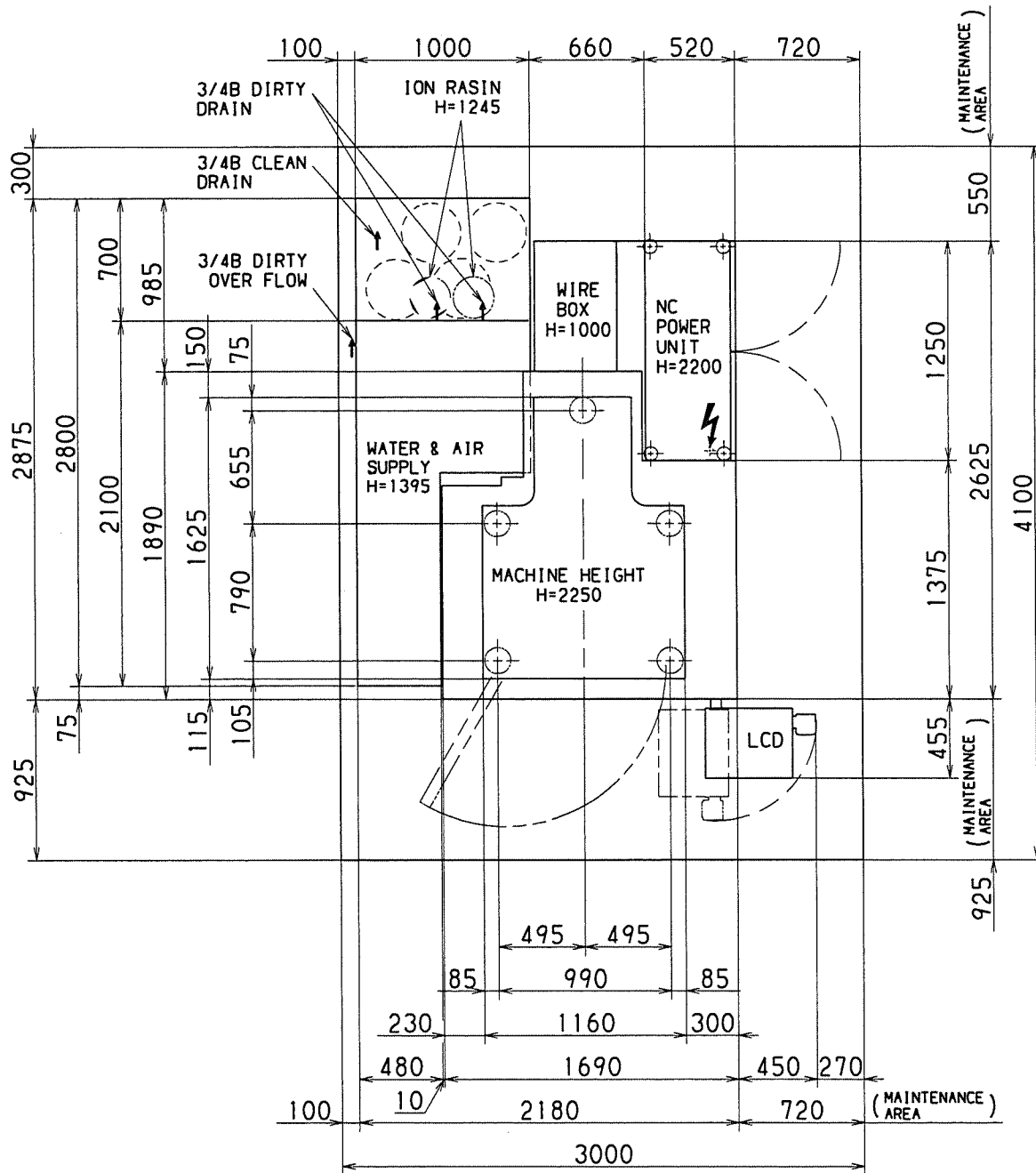

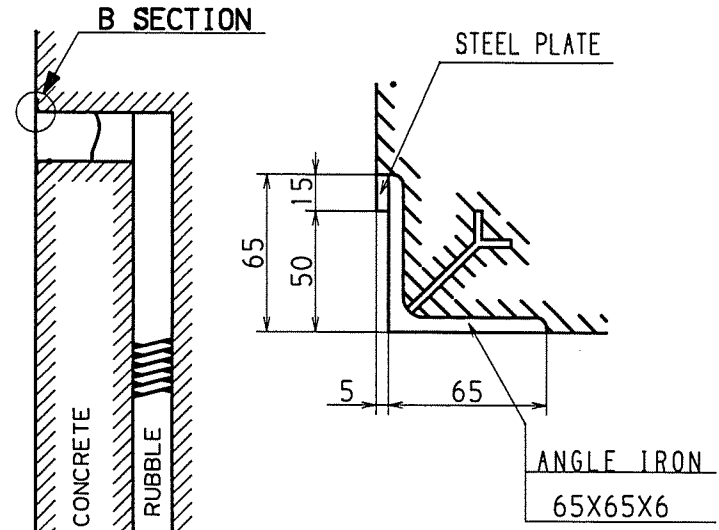
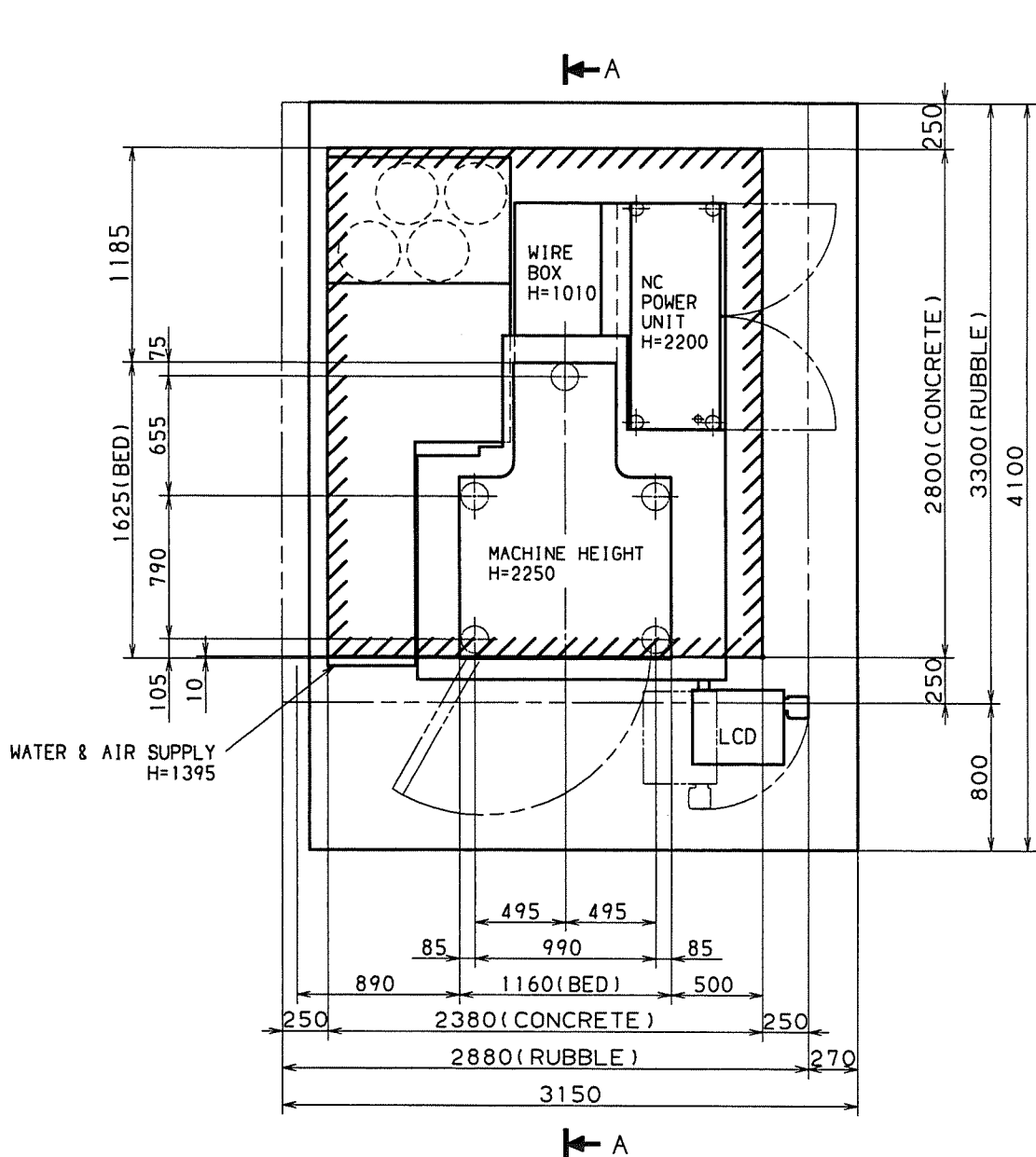

- MACHINE MASS 3,400 Kg (INCLUDING NC POWER UNIT)
- W.&A.SUPPLY UNIT MASS 450 Kg
- WORK MASS(MAX) 800 Kg
- TANK CAPACITY 1,000 L



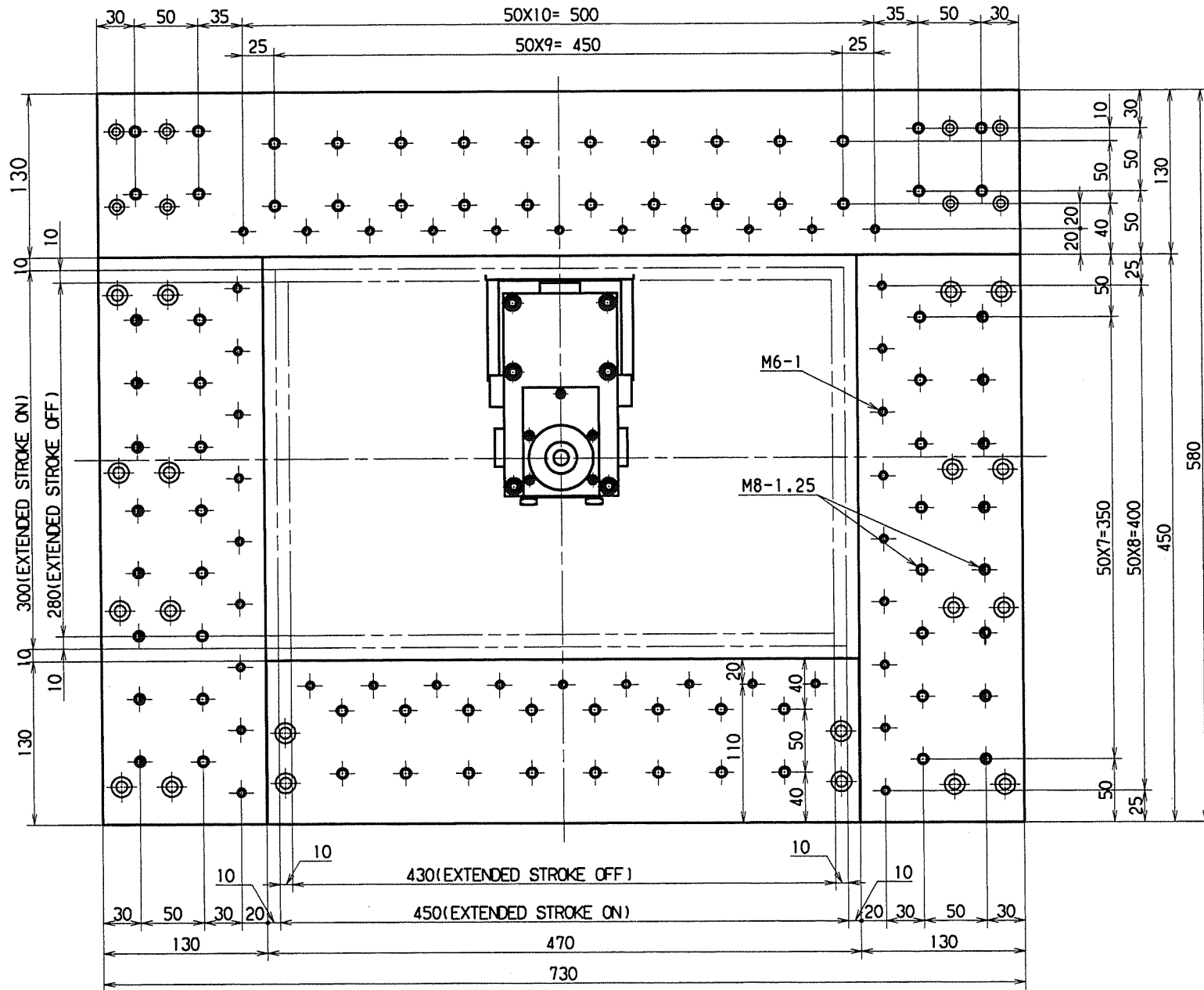
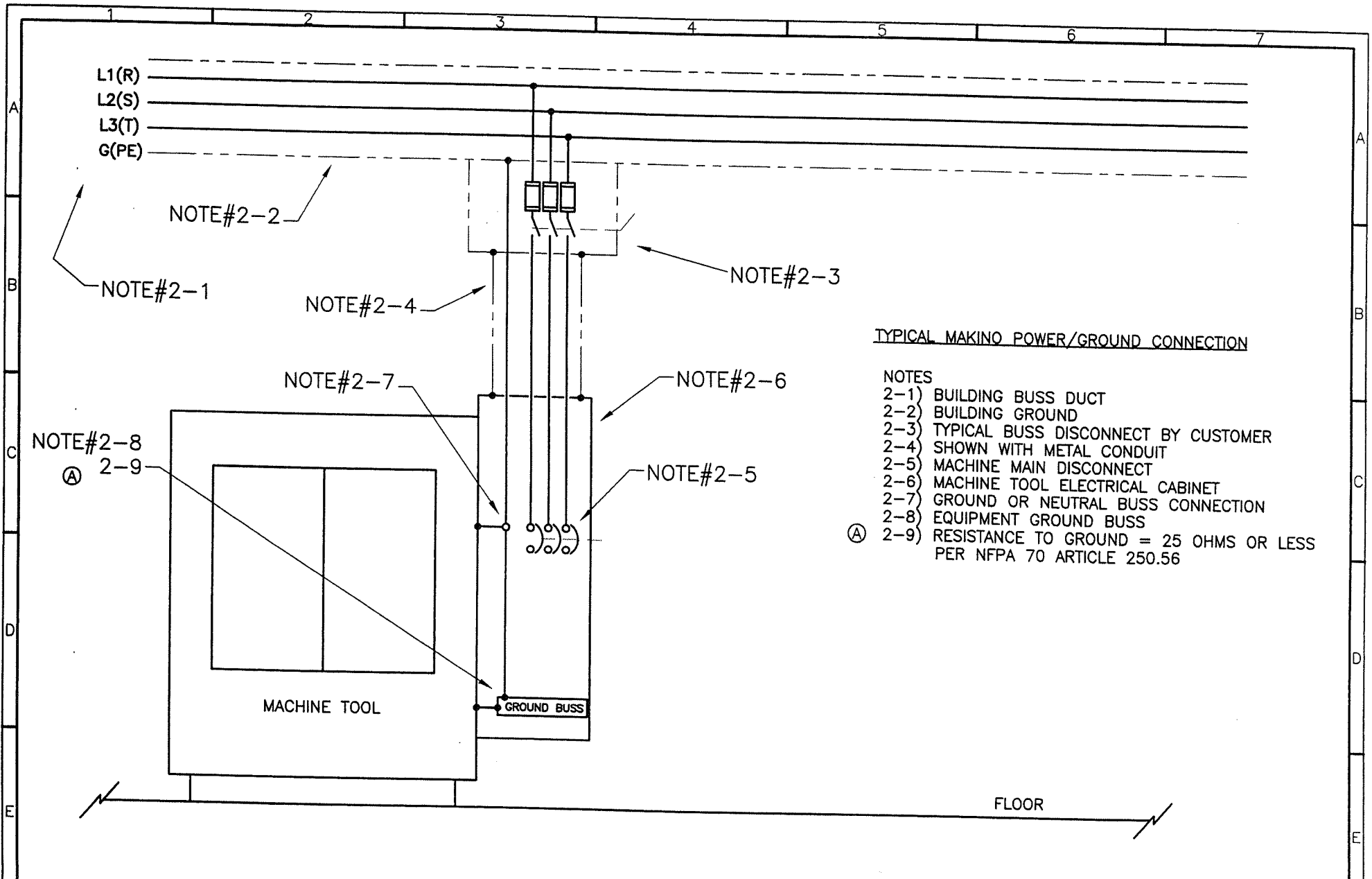

TABLE SHAPE SQUARE  
20EC910C401-01

CONTENTS				CONTENT			DRAWING NO.	PAGE	OPTION CHECK																												
CIRCUIT	MM SPECIAL OPTIONS	MACHINE GROUNDING CONTENT SHEET	(A)	EE7572	1																																
		TYPICAL MAKING POWER/GROUND CONNECTION (MM STANDARD)	(A)		2																																
		ALTERNATIVE MAKING POWER/GROUND RECOMMENDATION	(A)		3																																
		GROUND ELECTRODE CONDUCTOR WIRE SIZE PER NFPA AND CSA	(A)		4																																
		<div style="display: flex; justify-content: space-between; font-size: small;"> <div style="width: 30%;"> <table border="1" style="width: 100%; border-collapse: collapse;"> <tr> <td style="width: 5%;">(A)</td> <td style="width: 15%;">4</td> <td style="width: 40%;">CHANGED/ADDED VERBIAGE</td> <td style="width: 10%;">09/22/06</td> <td style="width: 10%;">N/A</td> <td style="width: 10%;">J.BOSSE</td> </tr> <tr> <td>(O)</td> <td>0</td> <td>DRAWING ISSUE</td> <td>N/A</td> <td>N/A</td> <td>N/A</td> </tr> <tr> <td style="font-size: x-small;">SUFFIX</td> <td style="font-size: x-small;">C.N.</td> <td style="font-size: x-small;">DESCRIPTION OF CHANGE</td> <td style="font-size: x-small;">DATE</td> <td style="font-size: x-small;">ECO NO.</td> <td style="font-size: x-small;">CHANGED BY</td> </tr> </table> </div> <div style="width: 30%; text-align: center;"> <p style="margin: 0;"><b>MAKINO</b></p> </div> <div style="width: 30%;"> <table border="1" style="width: 100%; border-collapse: collapse;"> <tr> <td style="width: 50%; text-align: center;">TITLE</td> <td style="width: 10%;">MACHINE TYPE</td> <td style="width: 10%;">DRAWING No.</td> <td style="width: 25%;">GROUP</td> </tr> <tr> <td style="text-align: center;">MACHINE GROUNDING</td> <td>ALL</td> <td style="text-align: center;">EE7572</td> <td>MM EE</td> </tr> <tr> <td> </td> <td>NC TYPE</td> <td> </td> <td>SHEET No.</td> </tr> <tr> <td> </td> <td>BOM</td> <td> </td> <td>1 OF 4</td> </tr> </table> </div> </div>		(A)	4	CHANGED/ADDED VERBIAGE	09/22/06	N/A	J.BOSSE	(O)	0	DRAWING ISSUE	N/A	N/A	N/A	SUFFIX	C.N.	DESCRIPTION OF CHANGE	DATE	ECO NO.	CHANGED BY	TITLE	MACHINE TYPE	DRAWING No.	GROUP	MACHINE GROUNDING	ALL	EE7572	MM EE		NC TYPE		SHEET No.		BOM		1 OF 4
		(A)	4	CHANGED/ADDED VERBIAGE	09/22/06	N/A	J.BOSSE																														
(O)	0	DRAWING ISSUE	N/A	N/A	N/A																																
SUFFIX	C.N.	DESCRIPTION OF CHANGE	DATE	ECO NO.	CHANGED BY																																
TITLE	MACHINE TYPE	DRAWING No.	GROUP																																		
MACHINE GROUNDING	ALL	EE7572	MM EE																																		
	NC TYPE		SHEET No.																																		
	BOM		1 OF 4																																		



TYPICAL MAKINO POWER/GROUND CONNECTION

NOTES

- 2-1) BUILDING BUSS DUCT
- 2-2) BUILDING GROUND
- 2-3) TYPICAL BUSS DISCONNECT BY CUSTOMER
- 2-4) SHOWN WITH METAL CONDUIT
- 2-5) MACHINE MAIN DISCONNECT
- 2-6) MACHINE TOOL ELECTRICAL CABINET
- 2-7) GROUND OR NEUTRAL BUSS CONNECTION
- 2-8) EQUIPMENT GROUND BUSS
- Ⓐ 2-9) RESISTANCE TO GROUND = 25 OHMS OR LESS PER NFPA 70 ARTICLE 250.56

Ⓐ	2	CHANGED/ADDED VERBIAGE	09/22/06	N/A	J.BOSSE
⓪	0	DRAWING ISSUE	N/A	N/A	N/A
SUFFIX	I.C.N.	DESCRIPTION OF CHANGE	DATE	ECO NO.	CHANGED BY
DESIGN:	J.BOSSE	DATE:	APPROVED: J.BROWN	DATE: 08/02/06	
DRAWN:	J.BOSSE	DATE: 08/02/06	CHECKED: J.BOLAND	DATE: 08/02/06	



TITLE  
MACHINE GROUNDING

MACHINE TYPE	ALL
NC TYPE	ALL
BOM	N/A

DRAWING No.	GROUP
EE7572	MM EE
	SHEET No.
	2 OF 4

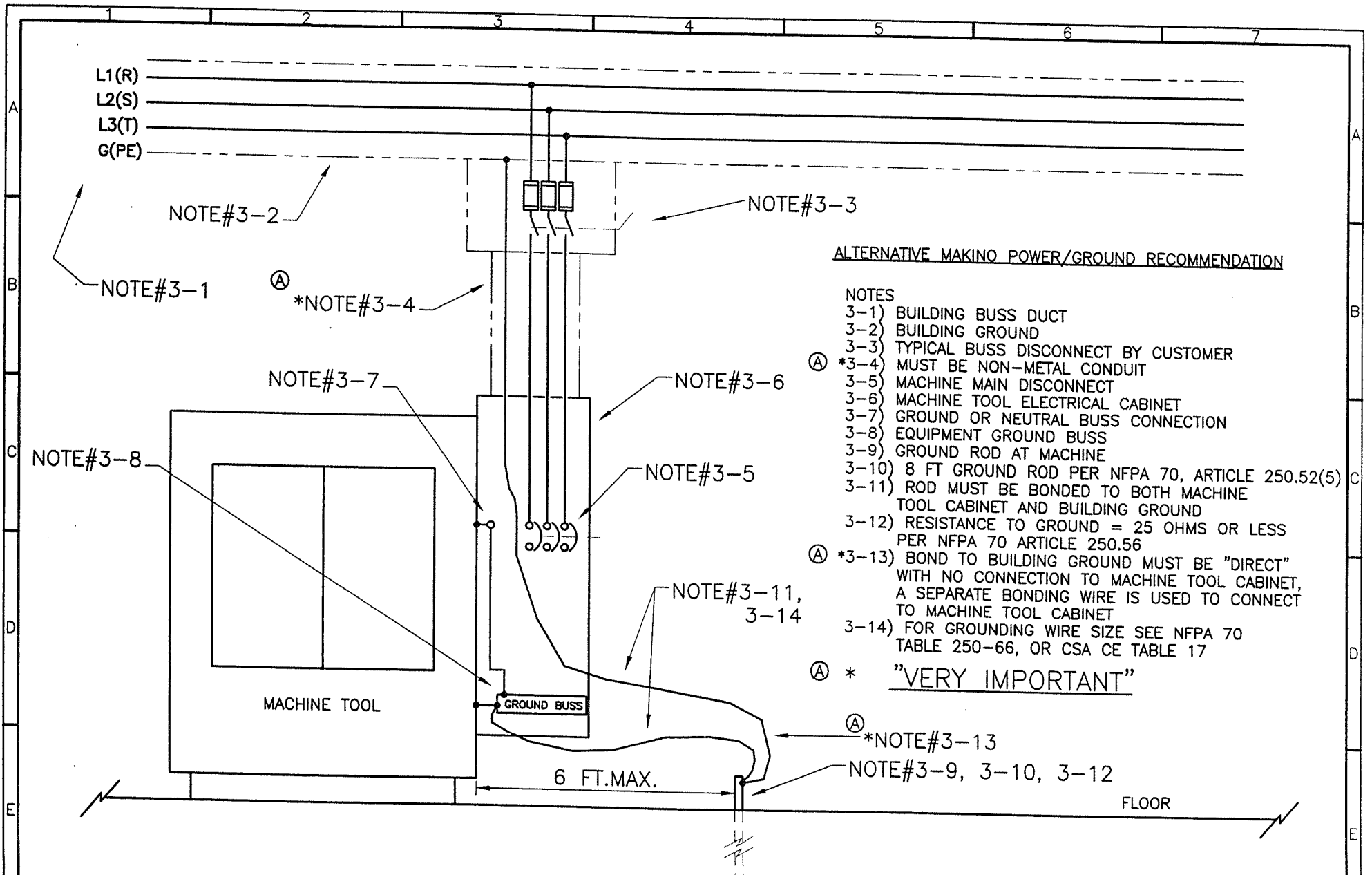

ALTERNATIVE MAKINO POWER/GROUND RECOMMENDATION

NOTES

- 3-1) BUILDING BUSS DUCT
- 3-2) BUILDING GROUND
- 3-3) TYPICAL BUSS DISCONNECT BY CUSTOMER
- (A) \*3-4) MUST BE NON-METAL CONDUIT
- 3-5) MACHINE MAIN DISCONNECT
- 3-6) MACHINE TOOL ELECTRICAL CABINET
- 3-7) GROUND OR NEUTRAL BUSS CONNECTION
- 3-8) EQUIPMENT GROUND BUSS
- 3-9) GROUND ROD AT MACHINE
- 3-10) 8 FT GROUND ROD PER NFPA 70, ARTICLE 250.52(5)
- 3-11) ROD MUST BE BONDED TO BOTH MACHINE TOOL CABINET AND BUILDING GROUND
- 3-12) RESISTANCE TO GROUND = 25 OHMS OR LESS PER NFPA 70 ARTICLE 250.56
- (A) \*3-13) BOND TO BUILDING GROUND MUST BE "DIRECT" WITH NO CONNECTION TO MACHINE TOOL CABINET, A SEPARATE BONDING WIRE IS USED TO CONNECT TO MACHINE TOOL CABINET
- 3-14) FOR GROUNDING WIRE SIZE SEE NFPA 70 TABLE 250-66, OR CSA CE TABLE 17

(A) \* "VERY IMPORTANT"

(A) \*NOTE#3-13

NOTE#3-9, 3-10, 3-12

(A) 5	CHANGED/ADDED VERBIAGE	09/22/06	N/A	J.BOSSE	
(O) 0	DRAWING ISSUE	N/A	N/A	N/A	
SUFFIX	C.N.	DESCRIPTION OF CHANGE	DATE	ECO NO.	CHANGED BY
DESIGN:	J.BOSSE	DATE:	APPROVED:	J.BROWN	DATE: 08/02/06
DRAWN:	J.BOSSE	DATE: 08/02/06	CHECKED:	J.BOLAND	DATE: 08/02/06



TITLE		MACHINE TYPE	ALL	DRAWING No.	GROUP
MACHINE GROUNDING		NC TYPE	ALL	EE7572	MM EE
		BOM	N/A		SHEET No.

GROUNDING ELECTRODE CONDUCTOR WIRE SIZE  
IN RELATIONSHIP TO MACHINE SERVICE  
CONDUCTOR WIRE SIZE PER NFPA 70, TABLE 250.66

(A)	SERVICE CONDUCTOR WIRE SIZE (AWG/kcmil) COPPER	GROUND ELECTRODE WIRE SIZE (AWG) COPPER NOT LESS THAN
	2 OR SMALLER	8
	1 OR 1/0	6
	2/0 OR 3/0	4
(A)	OVER 3/0 THROUGH 350 kcmil	2
	OVER 350 THROUGH 600	1/0
	OVER 600 THROUGH 1100	2/0
	OVER 1100	3/0

GROUNDING ELECTRODE CONDUCTOR WIRE SIZE  
IN RELATIONSHIP TO MACHINE SERVICE  
AMPACITY PER CSA CE TABLE 17

SERVICE AMPACITY	GROUND ELECTRODE WIRE SIZE (AWG) COPPER NOT LESS THAN
100 OR LESS	8
101 TO 125	6
126 TO 165	4
166 TO 200	3
201 TO 260	2
261 TO 355	0
356 TO 475	00
OVER 475	000

SUFFIX	C.N.	DESCRIPTION OF CHANGE	DATE	ECO NO.	CHANGED BY
(A)	2	CHANGED/ADDED VERBIAGE	09/22/06	N/A	J.BOSSE
(D)	0	DRAWING ISSUE	N/A	N/A	N/A

DESIGN:	J.BOSSE	DATE:		APPROVED:	J.BROWN	DATE:	08/02/06
DRAWN:	J.BOSSE	DATE:	08/02/06	CHECKED:	J.BOLAND	DATE:	08/02/06



TITLE  
MACHINE GROUNDING

MACHINE TYPE  
**ALL**

NC TYPE  
ALL

BOM  
N/A

DRAWING No.

EE7572

GROUP  
MM EE

SHEET No.  
4 OF 4