

VTC SERIES

200C | 200G | 300C | 250D/50 | 800/30 SR | 805E | 805G

Mazak

TABLE OF CONTENTS

Introduction	3
Optimum Plus Service and Support	4-5
Top 10 Advantages	6
Machine Design	7
Spindle Power and Speeds	8-9
Fast, Easy and Efficient Programming	10-11
MAZATROL Controls	12-17
Optional Equipment	18
Mazak Automation Systems.....	19
Mazak Digital Solutions.....	20-21
External Dimensions.....	22-35
Machine Specifications	36
High Accuracy	37
Spindle and Unit Rebuild	38
Environmentally Friendly.....	39
Mazak Technology + Technical Centers	40-41
Financing	42
Resources and Links	43

VTC SERIES

SIZE, SPEED AND POWER

Built in Kentucky, the [VTC Series](#) of vertical machining centers bring high versatility and productivity to the machining of extremely long and heavy workpieces. A full traveling column design, fixed tables, increased spindle speeds and torque, along with new Smooth CNC controls on some models, make machines in the VTC series perfect for long aerospace parts, conveyor sections, castings for construction machinery and more.

To further enhance part processing versatility, an optional table center partition creates two separate work areas and large-capacity tool magazines deliver uninterrupted, continuous machine operation. VTC Series machines can also be outfitted with rotary tables.

MAZATROL SmoothG CNC

- [VTC-805E](#)
- [VTC-805G](#)

MAZATROL MATRIX NEXUS 2 CNC

- [VTC-200C](#)
- [VTC-200G](#)
- [VTC-300C](#)
- [VTC-250D/50](#)

MAZATROL MATRIX 2 CNC

- [VTC-800/30 SR](#)

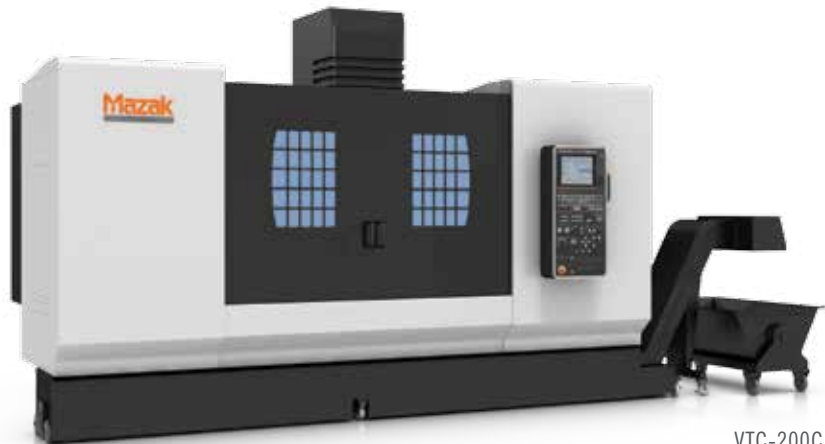

VTC-200C

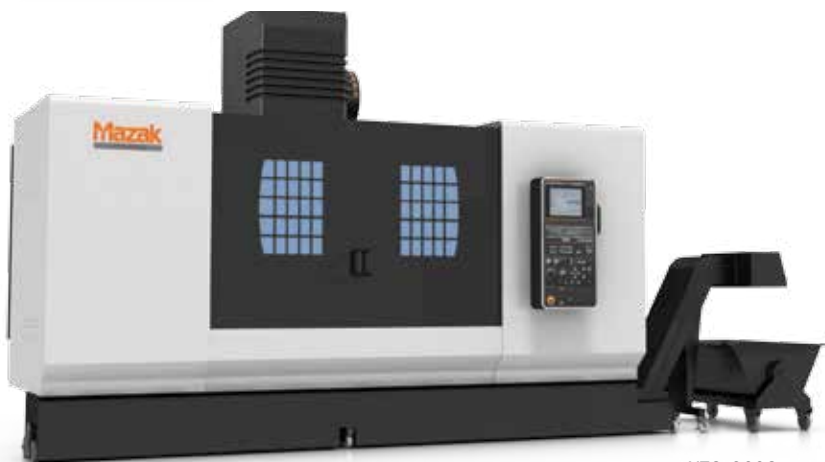

VTC-300C



VTC-805G

OPTIMUM PLUS SERVICE AND SUPPORT

MAZAK OPTIMUM PLUS

To maximize machine tool investments, the [Mazak Optimum Plus](#) program represents a company-wide commitment to provide the best possible, most comprehensive support.

The Optimum Plus program encompasses Five Pillars — distinct, yet interrelated areas:

- Single-source service
- Technical support — machine and CNC
- Parts support
- Progressive Learning
- Spindle and unit rebuild

Single-source service

Mazak is a single point of contact for any Mazak-related service need, whether it involves a machine, control, accessory or automation solution. This effective service approach helps customers maintain the highest possible level of productivity.

Benefits of [Mazak's single-source approach](#) include:

- Free technical phone support and software upgrades for the life of a Mazak machine
- Software support that provides instantaneous diagnostic services via remote real-time systems
- Guaranteed phone response to any technical question within one hour via a 24/7 technical phone support system
- More than 350 factory-trained Mazak service representatives and certified distributor personnel that can be at a customer's site within 24 hours under most circumstances
- Wide variety of services, including laser calibration to ISO, ANSI and JIS standards; ball bar qualification and analysis; preventive maintenance plans and programs; and vibration analysis and benchmarking

Technical support — machine and CNC

Comprehensive warranties on every Mazak machine tool component, including a two-year part warranty on CNC control components.

[Technical support](#) for machines and CNCs also includes:

- Additional warranty coverage (available upon request)

Mazak OPTIMUMplus

TOTAL SUPPORT FOR MAZAK CUSTOMERS

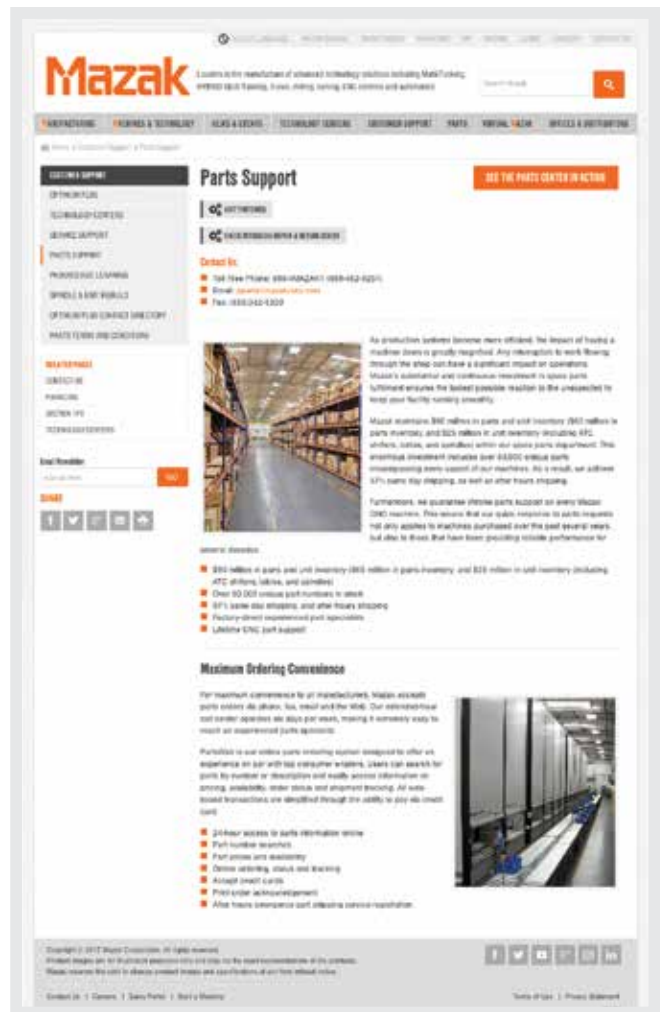

THE MAZAK OPTIMUM PLUS PROGRAM ENABLES CUSTOMERS TO MAXIMIZE THE VALUE OF THEIR MAZAK PURCHASE.

Parts support

Mazak's spare parts fulfillment ensures the fastest possible reaction time. The state-of-the-art Mazak North American Parts Center uses the latest AS/RS fully automated warehouse storage system technology and maintains a \$65 million parts inventory.

Benefits of the North American Parts Center include:

- Average 97% same day parts shipment and after hours shipping
- 52,000 part numbers in stock
- Call center open Monday-Saturday
- Convenient web-based parts ordering
- Experienced part specialists
- Lifetime CNC parts support

[Click here for more information on parts support.](#)



FULLY AUTOMATED WAREHOUSE STORAGE SYSTEMS ENSURE THE FASTEST DELIVERY OF MAZAK SPARE PARTS.

Progressive Learning

[Mazak's Progressive Learning](#) represents a unique, phased approach to education and training for customers, combining hands-on training, web-based instruction and real-world examples. The program's tiers of offerings — Pyramid of Learning — range from self-paced coursework to highly advanced classes. Every Mazak machine includes three years of programming training at no charge to customers.

[Mazak's Pyramid of Learning](#) is a visual representation of its approach to training. The lower levels at the base of the pyramid represent basic skills education for new machinists, while the upper levels signify advanced training for highly experienced programmers and operators.

Pyramid of Learning levels include:

- Simple online training
- Introductory programming training
- Traditional hands-on training
- Advanced training
- Customized training

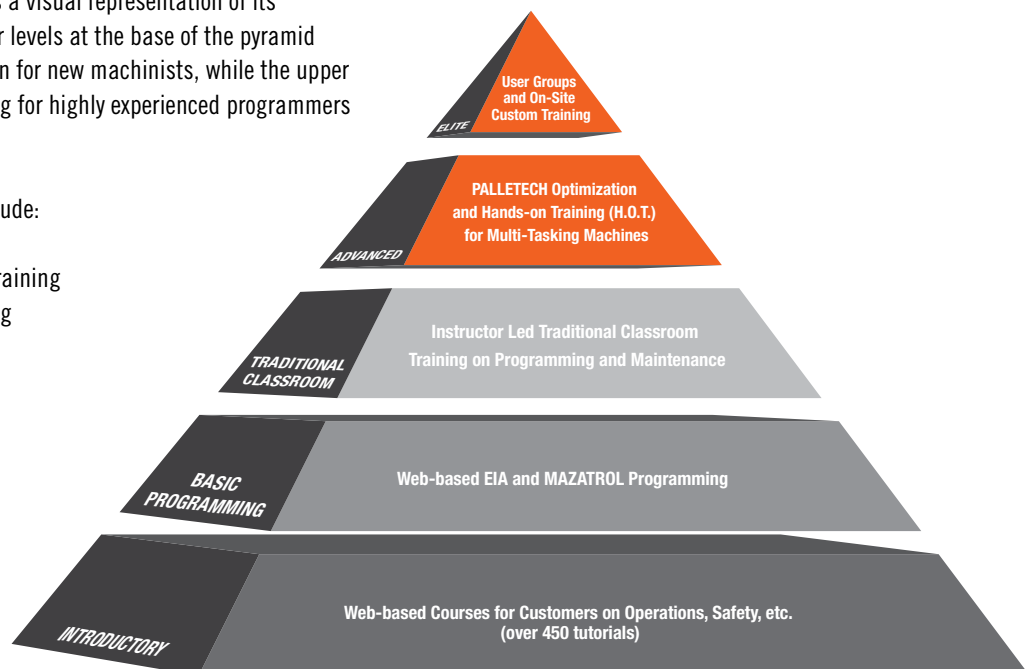

TOP 10 ADVANTAGES OF THE VTC SERIES

VTC Series machines feature several new and innovative technologies to help job shops boost speed, performance and precision in a wide variety of metalworking applications. The series brings advanced technology, value and productivity to part-processing operations.

1. **Full traveling column design and fixed tables** for machining extremely long and heavy workpieces.
2. **Increased Y-axis stroke** for cost-effective alternative to bridge-style machines.
3. **Optional table partition** transforms table into two separate work areas.
4. **Base casting design** allows excellent chip flow and reduces thermal distortion.
5. **Robust high-performance spindles** offered in various maximum speeds/torque.
6. **Mazak MAZATROL Smooth Controls** offer fast and easy EIA/ISO and conversational programming.
7. **Large-capacity tool magazines with automatic tool changers** extend uninterrupted, continuous machine operation.
8. **Mazak MX Hybrid Roller Guide System** delivers durability, reliability and long-term accuracy.
9. **Optional seamless automation integration** increases uptime and lights-out production.
10. **Green, energy efficient and ergonomic features** make for ease of use, environmentally friendly, low-maintenance operation.



VTC-805E



MACHINE DESIGN

Machines in the VTC Series bring together the perfect blend of features to deliver the speed, power and rigidity required for the machining of large and/or heavy components. Plus, an optional center partition transforms the machine into two work areas for efficient processing of smaller parts.

BASE

VTC machine base casting designs provide enhanced rigidity to handle heavy loads, excellent chip flow and reduced thermal distortion.

FIXED TABLE

Long fixed tables securely hold parts and support heavy workpieces not suited for machines with moving tables.

TRAVELING COLUMN

Full traveling columns house both the spindles and large capacity tool magazines of VTC machines to enable highly productive, accurate and interference-free part processing. Because tool magazines travel along with spindles, tool changes are extremely fast and non-cut time is significantly reduced.

CENTER PARTITION

For even greater flexibility, optional table center partitions divide the machine work envelopes into two separate work areas. This allows the machine to be in cycle in one work area, while a part is being unloaded/loaded or a new set up is occurring in the other work area.

AMPLE Y AXIS

VTC Series machines offer the industry's largest Y-axis stroke up to 32.0" to give shops a cost-effective alternative to bridge-style machines for the production of large, heavy parts.

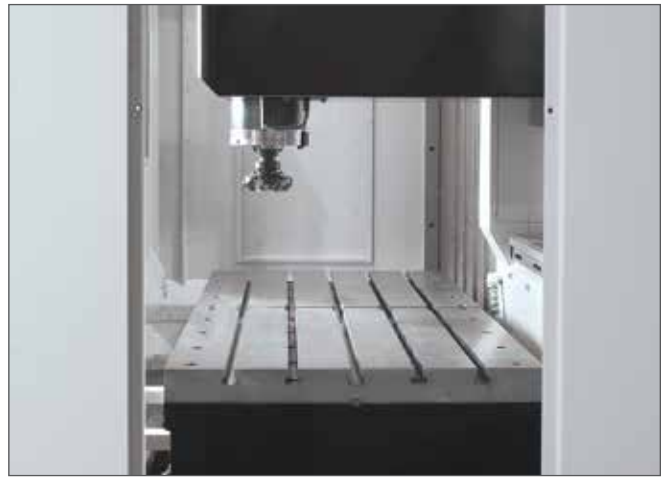

FIXED TABLE

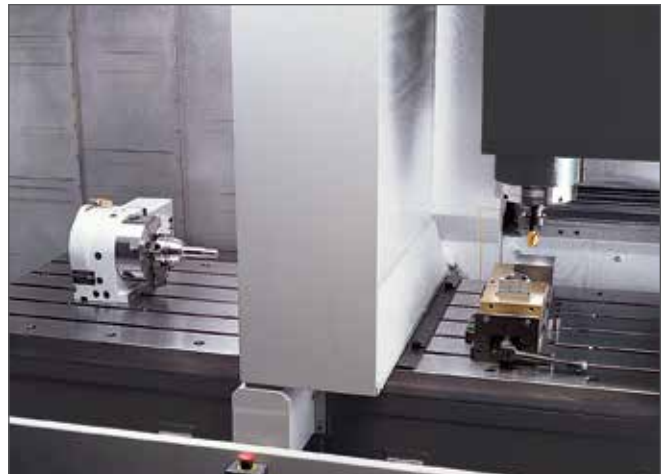

CENTER PARTITION

SPINDLES

VTC Series machines feature powerful, rigid spindles positioned on full traveling columns to give shops what they need to achieve high productivity and maintain exceptional accuracy. Standard machine spindles deliver unbeatable metal removal capabilities for all common materials, including steels, aluminums and cast irons. Mazak also offers other maximum spindle speeds/torques so that shops can effectively match spindle performance to specific part machining needs.

On the VTC-800/30 SR, a swivel spindle head tilts +/- 110 degrees in the B axis to deliver improved accuracy and repeatability. The addition of the B-axis allows the machining of complex features and contours to significantly reduce machining processes and increase productivity.

40 TAPER

40-taper spindles provide an effective and productive balance of speed and torque for heavy-duty and high-speed cutting of aluminum and other non-ferrous materials.

- 12,000 rpm – VTC-200C, 200G, 300C
- 18,000 rpm – VTC-800/30 SR

50 TAPER

High-torque 50-taper spindles with maximum torque ratings ranging from 122 ft-lb to over 665 ft-lb provide the strength and power for aggressive metal removal in tough-to-machine materials.

- 6,000 rpm – VTC-250D/50, 805E, 805G
- 10,000 rpm (optional) – VTC-805E, 805G

VTC-200C, VTC-200G AND VTC-300C
POWER-TORQUE 40–12,000 MIN⁻¹ (RPM)

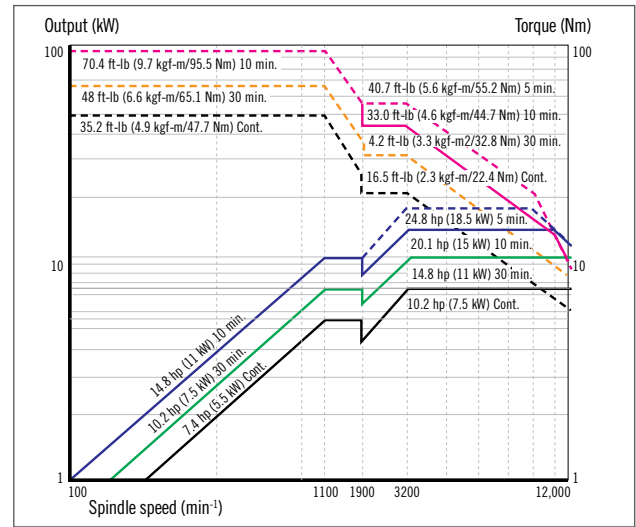

(FOR REFERENCE ONLY)

VTC-800/30 SR POWER-TORQUE 35–18,000 MIN⁻¹ (RPM)

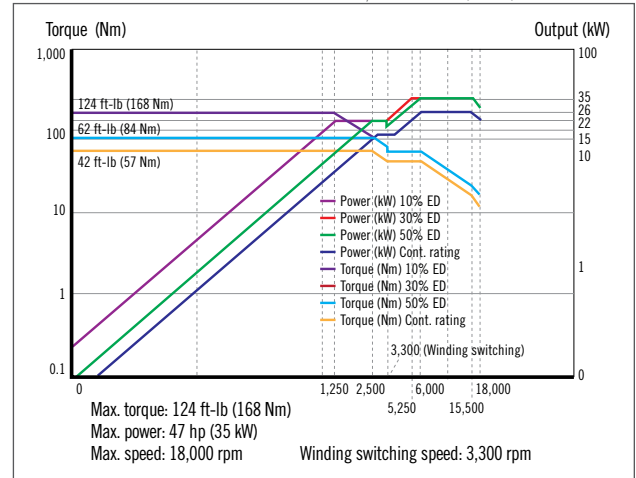

(FOR REFERENCE ONLY)

VTC-805E AND VTC-805G
POWER-TORQUE 35–10,000 MIN⁻¹ (RPM) – OPTIONAL

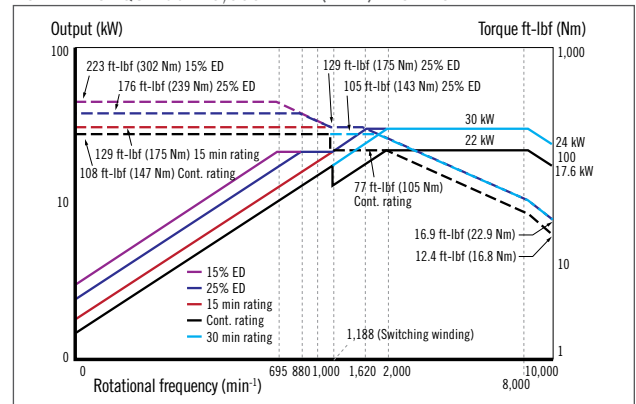

(FOR REFERENCE ONLY)

VTC-250D/50, VTC-805E AND VTC-805G
 POWER-TORQUE 26–6,000 MIN⁻¹ (RPM) – STANDARD
 50 TAPER AC SPINDLE MOTOR 30HP (LOW GEAR)

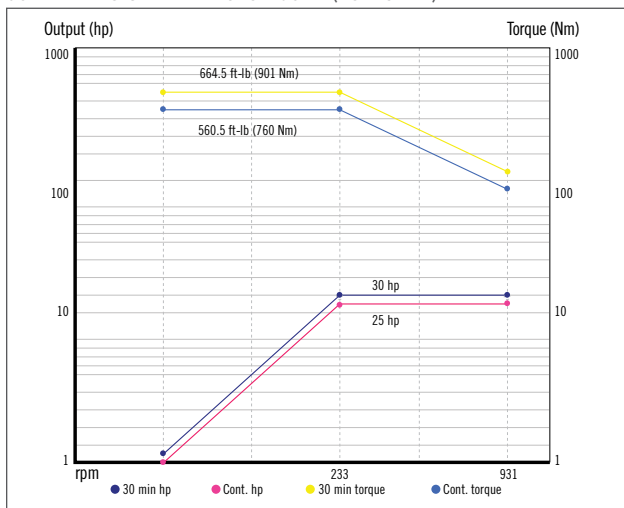

(FOR REFERENCE ONLY)

VTC-250D/50, VTC-805E AND VTC-805G
 POWER-TORQUE 26–6,000 MIN⁻¹ (RPM) – STANDARD
 50 TAPER AC SPINDLE MOTOR 30HP (HIGH GEAR)

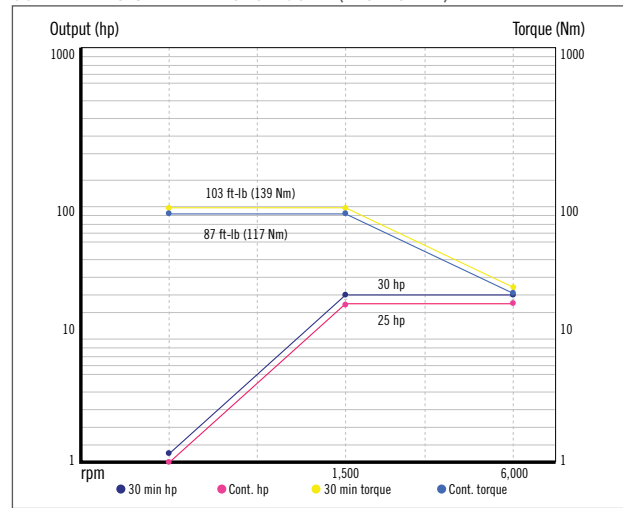

(FOR REFERENCE ONLY)

AUTOMATIC TOOL CHANGERS AND TOOL STORAGE

For part production versatility, each VTC Series machine features an automatic tool changer and large capacity tool storage. The tool magazine travels with the machine's column to reduce non-cut time by quickly exchanging tools and getting the machine back in the cut in the shortest times possible.

- 24-, 30- or 40-tools standard (depending on model)
- 48-tool only on 200C/200G/300C



FAST, EASY AND EFFICIENT PROGRAMMING

The continuously innovative Mazak MAZATROL SMOOTH CNC controls make programing VTC Series machines easy, fast and efficient. The highly versatile controls allow for both [EIA/ISO and conversational programming](#), while other features and capabilities boost power and functionality.

EIA/ISO COMPATIBILITY STANDARD

MAZATROL G-codes are the same as those used in conventional EIA CNC machines. This allows VTC Series machine users to run programs made for other machine brands by simply editing M codes and confirming axis strokes along with cutting conditions.

CONVERSATIONAL PROGRAMMING

The industry standard MAZATROL conversational programming makes it possible for inexperienced operators to quickly and easily develop machining programs for VTC Series machines. Operators answer conversationally displayed questions concerning the intended workpiece. These queries include type of material, OD/ID dimensions, part lengths and several others. Then, according to the input data, the MAZATROL control automatically calculates intersection coordinates and tool index positioning in addition to optimized cutting conditions and machining processes.



SMOOTHG CONTROL SCREEN

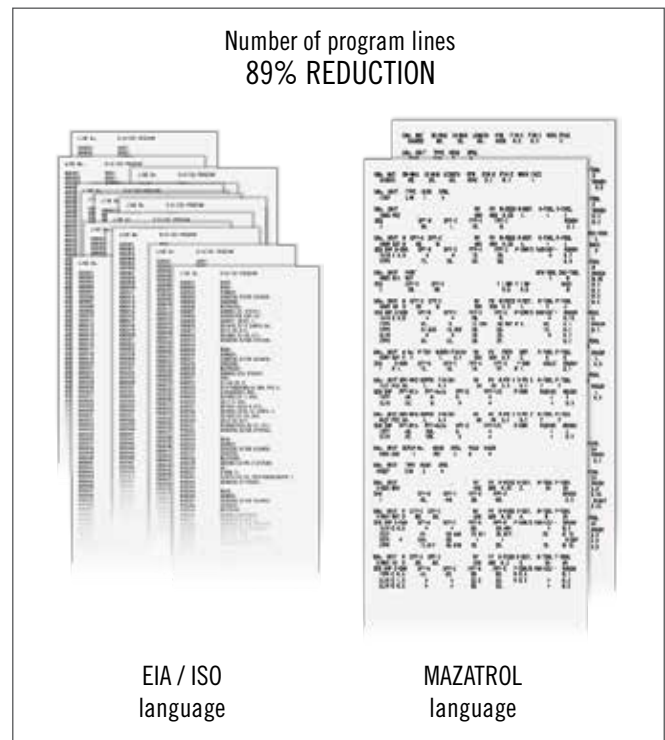

PROCESS HOME SCREENS

Innovative touch operation of the MAZATROL SMOOTH controls streamlines data entry and minimizes the number of displays to reduce programming times for VTC Series machines. Five different home process screens each display their appropriate data in an easy to understand manner. Operators can touch icons to quickly navigate to additional screen displays.

Process home screens include:

- Programming
- Tool data
- Setup
- Machining
- Maintenance



SMOOTHG PROGRAMMING SCREEN

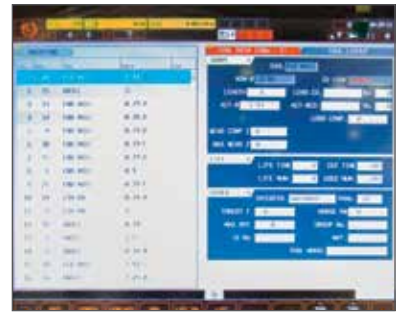

SMOOTHG TOOL DATA SCREEN



SMOOTHG MACHINING SCREEN



SMOOTHG MAINTENANCE SCREEN

MAZATROL SmoothG CONTROL

The **MAZATROL SmoothG CNC** makes it easy to generate programs for processing complex parts through off-centerline machining as well as angled drilling, milling and tapping. The control incorporates a wide variety of advanced programming functions that allow it to offer complete ease of use and ensure high-speed, high-accuracy machining performance.

Machine models:

- VTC-805E
- VTC-805G

FEATURES AND FUNCTIONS OF THE MAZATROL SmoothG CONTROL INCLUDE:

- **Virtual Machining** allows operators to perfect part programs prior to initiating cutting
- **High Gain Feed Forward Control** boosts machining speed and accuracy
- **Fast Rotary Axis Speeds** optimize gear skiving and rotary axis threading
- **Variable Acceleration Control** calculates optimal acceleration for a combination of axes
- **Position-Controlled Hobbing** provides fast, convenient hobbing and skiving operations
- **Real Time Tuning** ensures optimal machining balance as workpiece weight changes
- **Quick MAZATROL** makes it possible to directly import 3D CAD models into the control and automatically extract coordinates from it to simply machine programming
- **Quick EIA** plots toolpaths prior to running programs and checks for any interferences in those paths
- **EIA/ISO and Conversational Programming Capabilities**



MAZATROL SmoothG SPECIFICATIONS

	MAZATROL	EIA
Number of controlled axes	Simultaneous 2 ~ 4 axes	
Least input increment	0.00001 inch, 0.0001 mm, 0.0001°	
High speed, high-precision control	Shape error designation, Smooth corner control, Rapid traverse overlap, Rotary axis shape compensation	Shape error designation, Smooth corner control, Rapid traverse overlap, Rotary axis shape compensation, High-speed machining mode, High-speed smoothing control function
Interpolation	Positioning (Linear interpolation), Positioning (Independent interpolation), Linear interpolation, Circular interpolation, Cylindrical coordinate interpolation, Polar coordinate interpolation, Synchronized milling spindle tapping*	Positioning (Linear interpolation), Positioning (Independent interpolation), Linear interpolation, Circular interpolation, Spiral interpolation, Helical interpolation, Cylindrical coordinate interpolation*, Fine spline interpolation*, NURBS interpolation*, Polar coordinate interpolation*, Synchronized milling spindle tapping*
Feed rate	Rapid traverse, Cutting feed, Cutting feed (per minute), Cutting feed (per revolution), Dwell (specified time, specified number of rotation), Rapid traverse override, Cutting feed override, G0 speed variable control, Feedrate clamp, Variable acceleration/deceleration control, Constant control for G0 tilting*	Rapid traverse, Cutting feed, Cutting feed (per minute), Cutting feed (per revolution), Inverse time feed, Dwell (specified time, specified number of rotation), Rapid traverse override, Cutting feed override, G0 speed variable control, Feedrate clamp, Time constant changing for G1, Variable acceleration/deceleration control, Constant control for G0 tilting*
Program registration	Max. number of programs: 960, Program storage: 2 MB, Program storage expansion: 8 MB*, Program storage expansion: 32 MB*	
Control display	Display: 19" touch panel, Resolution: SXGA	
Spindle functions	S code output, Spindle speed clamp, Spindle speed override, Spindle speed reaching detection, Multiple position orient, Constant surface speed, Spindle speed command with decimal digits, Synchronized spindle control, Max. speed control for spindle	
Tool functions	Tool offset pairs: 4000, T code output for tool number, Tool life monitoring (time), Tool life monitoring (number of machined workpieces)	Tool offset pairs : 4000, T code output for tool number, T code output for group number, Tool life monitoring (time), Tool life monitoring (number of machined workpieces)
Miscellaneous functions	M code output, Simultaneous output of multiple M codes	
Tool offset functions	Tool position offset, Tool length offset, Tool diameter/tool nose R offset, Tool wear offset	
Coordinate system	Machine coordinate system, Work coordinate system, Local coordinate system, Additional work coordinates (300 set)	
Machine functions	—	Hobbing*, Shaping function*, Dynamic compensation II*
Machine compensation	G0/G1 independent backlash compensation, Pitch error compensation, Volumetric compensation*	
Protection functions	Emergency stop, Interlock, Stroke check before travelling, Retraction function for the vertical axis, INTELLIGENT SAFETY SHIELD (manual mode), INTELLIGENT SAFETY SHIELD (automatic mode)*, MAZAK VOICE ADVISER	
Automatic operation mode	Memory operation	Memory operation, Tape operation, MDI operation, EtherNet operation*
Automatic operation control	Optional stop, Dry run, Automatic handle control, MDI control, TPS, Restart, Machine lock	Optional block skip, Optional stop, Dry run, Automatic handle control, MDI control, TPS, Restart, Restart 2, Collation stop, Machine lock
Manual measuring functions	Tool length and tip teach, Touch sensor coordinates measurement, Workpiece offset measurement, WPC coordinate measurement, Measurement on machine	Tool length and tip teach, Tool offset teach, Touch sensor coordinates measurement, Workpiece offset measurement, WPC coordinate measurement, Measurement on machine
Automatic measuring functions	WPC coordinate measurement, Auto tool length measurement, Sensor calibration, Tool eye auto tool measurement, Tool breakage detection, External tool breakage detection*	Auto tool length measurement, Sensor calibration, Tool breakage detection, External tool breakage detection*
MDI measurement	Partial auto tool length measurement, Auto tool length measurement, Coordinate measurement	
Interface	PROFIBUS-DP*, EtherNet I/P*, CC-Link*	
Card interface	SD card interface, USB	
EtherNet	10 M / 100 M / 1 G bps	

* Option

MAZATROL MATRIX NEXUS 2 CONTROL

The [MATRIX NEXUS 2 CNC](#) simplifies operations for parts requiring angled drilling, milling or tapping. With unequalled innovation for conversational programming, the control incorporates a wide variety of advanced features for high-speed, high-accuracy machining and an overall increase in productivity.

Machine models:

- VTC-200C
- VTC-200G
- VTC-300C
- VTC-250D/50

FEATURES AND FUNCTIONS OF THE MAZATROL MATRIX NEXUS 2 INCLUDE:

- Simultaneous control of up to 4 axes
- 20GB hard disk offers increased program storage capacity
- High-speed CPU and large 12.1" CNC display sports multiple functions
- EIA/ISO and conversational programming offers versatility and user-friendly operation
- Sub-micron input delivers high-accuracy machining
- SMART functions streamline data entry and reduce programming time
- Virtual machining provides convenient program and interference checks



MAZATROL MATRIX NEXUS 2 SPECIFICATIONS

	MAZATROL	EIA
Number of controlled axes	Max. 4 axes (simultaneous 4 axes)	
Least input increment	0.00001 inch, 0.0001 mm, 0.0001°	
Max. programmable value	±9999.99999 inch, ±99999.9999 mm, ±99999.9999°	
High-precision control	Smooth high gain control, Scale feedback*, Absolute position detection	
Interpolation	Positioning (independent axes control, linear interpolation), Linear interpolation, Synchronized milling spindle tapping*	Positioning (independent axes control, linear interpolation), Linear interpolation, Synchronized milling spindle tapping*, Polar coordinate interpolation, Cylindrical coordinate interpolation*, Thread cutting (equal pitch, variable pitch), Polygon cutting*
Feed rate	Rapid traverse, Cutting feed (per revolution, per minute), Feedrate clamp, Override (rapid traverse, cutting feed, external override, 2nd override, override cancel), Automatic acceleration/deceleration feedrate (linear acc./dec., time constant), Constant tangential speed control, Dry run	
Program registration	256, 512*, 960* 2 MB (5,300 m), 8 MB (user area 7.7 MB, 20,000 m)	
Control display	12 inch color TFT	
NC display languages	English, German, French, Italian, Spanish, Dutch, Norwegian, Swedish, Finnish, Danish, Portuguese, Turkish, Polish, Czech, Romanian, Chinese simplified form, Chinese traditional form, Korean, Slovakian, Russian, Hungarian, Bulgarian, Japanese (one touch language switching) Note: Chinese (simplified/traditional), Korean, Russian and Japanese require same Windows language	
Windows languages	English, Chinese (simplified/traditional), Korean, Russian, Japanese (selection)	
Data input/output	USB, CF card*	
Protocol	MAZAK protocol*, Network protocol	
Interface	Card BUS*, Ethernet (1000 BASE-TX), PROFIBUS-DP*, EtherNet/IP*	
Spindle function	S code output (8-digit binary output, analog output, actual revolution speed binary output), Spindle revolution control (RPM clamping, high speed RPM confirm/speed change detection, rotary speed display), Spindle override (0–150%)	
Tool function	T code output (8-digit binary data, next tool, used tool), Tool life monitoring, Spare tool exchange, Tool management (Group No.)	
Tool compensation	Tool tip R compensation, Tool tip shape compensation, Tool position compensation, Tool wear compensation, Tool radius compensation	
Number of registered tools	Max. 4,000 (depends on machine specifications)	
Tool offset pairs	4,000 (depends on machine specifications)	
Miscellaneous functions	M code output (M3 - digit), Simultaneous output of four 3-digit M codes, Second miscellaneous function (B 3-digit output), High-speed MSTB interface	
Coordinate system control	MAZATROL coordinate system	Machine coordinate system (machine coordinate system, machine coordinate system shift, zero point shift), Work coordinate system(work coordinate system, work coordinate system shift)
Manual operation	Rapid traverse, Cutting feed, Handle feed, Zero point return, Manual control (machine lock, gear shift, barrier cancel), Manual spindle control (spindle start, stop, reverse, jogging)	
Automatic operation	Memory operation, MDI operation, Cycle start, NC reset, Single block, Feed hold, Single process, Optional block skip, Optional stop, Machine lock, Feed override, Spindle control, Dry run, Manual handle control, Tool path storage (TPS)	
Background functions	During automatic operation (programming, data input/output, tool path check)	
Machine compensation	Backlash compensation, Pitch error compensation, Rotational axis pitch error compensation, Thermal displacement compensation	
Protection functions	Emergency stop, Over travel, Barrier (stored stroke limit, tool barrier), Interlock (cutting start, axis interlock), Alarm, Intelligent Safety Shield ¹ , Virtual Machining, Mazak Voice Adviser	
Measuring functions	Manual measurement (tool set measurement, Z-offset measurement), Automatic measurement (work offset measurement, Z-offset measurement, tool tip point measurement, external measurement), Measurement data printout	

*Option ¹ N/A in background

MAZATROL MATRIX 2 CONTROL

The **MATRIX 2 CNC** provides extremely fast processing speed, excellent cornering, superior part surface finishes and reduced cycle times. Through advanced hardware and software functionality, these controls bring high accuracy and increased productivity to highly complex applications requiring Multi-Tasking operations, full simultaneous 5-axis machining, and the incorporation of automation.

Machine model:

- VTC-800/30 SR

FEATURES AND FUNCTIONS OF THE MAZATROL MATRIX 2 INCLUDE:

- Large 19" color LCD display standard
- 9-axis (5-axis simultaneous capability)
- Faster processing through enhanced NC and PC hardware
- Customizable position screen
- 3D trace screen that offers less interruption
- Field network capability for flexible integration and minimal remote I/D
- High-speed continuous measurement functionality
- EIA/ISO and conversational programming offers versatility and user-friendly operation



MAZATROL MATRIX 2 SPECIFICATIONS

	MAZATROL	EIA/ISO
Number of controlled axes	Max. 8 axes (simultaneous 5 axes)	Max. 8 axes (simultaneous 5 axes)*
Least input increment	0.00001 inch, 0.00001 mm, 0.0001°	
Max. programmable value	±9999.99999 inch, ±99999.9999 mm, ±99999.9999°	
High-precision control	Smooth high gain control, Scale feedback*, Absolute position detection	
Interpolation	Positioning (independent axes control, linear interpolation), Linear interpolation, Synchronized milling spindle tapping*	Positioning (independent axes control, linear interpolation), Linear interpolation, Synchronized milling spindle tapping*, Polar coordinate interpolation, Cylindrical coordinate interpolation*, Helical interpolation, Polygon cutting*, Hobbing*, Thread cutting (equal pitch, variable pitch)
Feed rate	Rapid traverse, Cutting feed (per revolution, per minute), Feedrate clamp, Override (rapid traverse, cutting feed, external override, 2nd override, override cancel), Automatic acceleration/deceleration feedrate (linear acc./dec., time constant), Constant tangential speed control, Dry run	
Multi-Tasking machine control	Continuous control of second spindle, Phase matching, Axes torque control	
Program registration	256, 512*, 960* 2 MB (5,300 m), 8 MB (user area 7.7 MB, 20,000 m)	
Control display	15 inch color TFT	
NC display languages	English, German, French, Italian, Spanish, Dutch, Norwegian, Swedish, Finnish, Danish, Portuguese, Turkish, Polish, Czech, Romanian, Chinese (simplified), Chinese (traditional), Korean, Slovakian, Russian, Hungarian, Bulgarian, Japanese, (simplified language switching)	
Windows languages	English, Chinese (simplified/traditional), Korean, Russian, Japanese (selection)	
Data input/output	USB, CF card	
Protocol	MAZAK protocol*, Network protocol	
Interface	Card BUS, Ethernet (1000 BASE-TX), PROFIBUS-DP*, EtherNet/IP*, SPRINT I/F*, CC-Link*	
Spindle function S code	S code output (8-digit binary output, analog output, actual revolution speed binary output), Spindle revolution control (RPM clamping, high speed RPM confirm/speed change detection, rotary speed display), Spindle override (0–150%)	
Tool function	T code output (8-digit binary data, next tool, used tool), Tool life monitoring, Spare tool exchange, Tool management (Group No.)	
Tool compensation	Tool length compensation, Tool diameter compensation, Tool tip R compensation, Tool wear compensation	
Number of registered tools	Max. 4,000	
Tool offset pairs	4,000	
Miscellaneous functions	M code output (M3 - digit), Simultaneous output of four 3-digit M codes, Second miscellaneous function (B 3-digit output), High-speed MSTB interface	
Coordinate system control	MAZATROL coordinate system	Machine coordinate system (machine coordinate system, machine coordinate system shift, zero point shift), Work coordinate system (work coordinate system, work coordinate system shift)
Manual operation	Rapid traverse, Cutting feed, Handle feed, Zero point return, Manual control (machine lock, gear shift, barrier cancel), Manual spindle control (spindle start, stop, reverse, jogging)	
Automatic operation	Memory operation, MDI operation, Cycle start, NC reset, Single block, Feed hold, Single process, Optional block skip, Optional stop, Machine lock, Barrier cancel, Feed override, Spindle control, Dry run, Manual handle control, Tool path storage (TPS)	Memory operation, MDI operation, Cycle start, NC reset, Single block, Feed hold, Single process, Optional block skip, Optional stop, Machine lock, Barrier cancel, Feed override, Spindle control, Dry run, Manual handle control, Tool path storage (TPS), Hard disc memory operation, Ethernet operation*, IC memory card operation*
Background functions	During automatic operation (programming, data input/output, tool path check)	
Machine compensation	Backlash compensation, Pitch error compensation, Rotational axis pitch error compensation, Thermal displacement compensation	
Protection functions	Emergency stop, Over travel, Barrier (stored stroke limit, chuck barrier, 2nd spindle chuck barrier, tailstock barrier, tool barrier), Interlock (cutting start, axis interlock), Alarm, Mazak Voice Adviser	
Measuring functions	Manual measurement (tool set measurement, workpiece offset measurement), Automatic measurement (workpiece measurement, tool measurement, external measurement), Measurement data printout	

*Option

OPTIONAL EQUIPMENT

Mazak offers a wide array of options from which to choose for the VTC Series that further enhance machine performance, increase uptime and boost overall operational efficiency.

- **Center table partition** that transforms the machine into two separate work areas to operate like a two-pallet changer
- **Rotary table units** add part accessibility and process flexibility
- **Part and tool probe packages** provide in-process workpiece measurement and automatically measure tool tip positions as well as detect wear/damage
- **High-power coolant** maximizes chip evacuation and contributes to longer cutting tool life
- **Mist collector** helps reduce maintenance costs and ensure a clean, safe work environment
- **Chip conveyor** designs for a wide variety of material types/ chip shapes

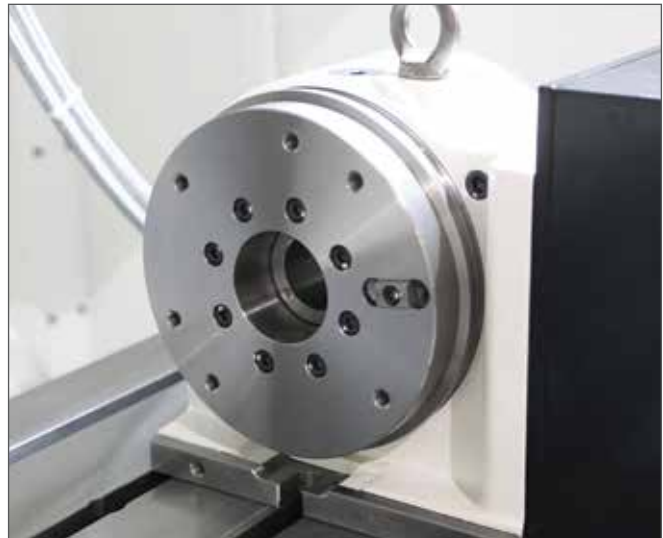

FOURTH-AXIS ROTARY TABLE



WORKPIECE PROBE



HIGH-POWER COOLANT



CHIP CONVEYOR



MIST COLLECTOR

MAZAK AUTOMATION SYSTEMS

Mazak automation further increases the productivity, throughput and part quality of the VTC Series machines. Standard and customized [Mazak automation solutions](#) paired with extensive and ongoing support ensure the best fit for individual production needs and that output goals are achieved.



ENGINEERED SOLUTIONS



CELLS AND SYSTEMS

ENGINEERED SOLUTIONS

Engineered Solutions encompass a variety of custom automation solutions tailored specifically to individual customer needs. Mazak's expert applications engineers design and implement systems and software that will boost productivity and ensure maximum return on customer automation investments.

Custom engineered solutions provide the capability to:

- Boost machine throughput and part quality
- Ensure production reliability and repeatability
- Service one or more machines with minimal operator intervention
- Perform multiple tasks and eliminate the number of necessary components in a system
- Keep machines running 24/7 without additional night or weekend shifts
- Reduce in-process inventory and accomplish just-in-time production



ARTICULATED ROBOT

ARTICULATED ROBOTS

[Articulated robots](#) automate part transfers and peripheral operations. They also eliminate the challenges associated with handling large, heavy or cumbersome parts. Robot configurations range from two jointed to seven jointed to meet the needs of various applications.

MAZAK DIGITAL SOLUTIONS

For the VTC Series and all its machines, Mazak offers digital solutions for fully integrated, data-driven smart manufacturing. These progressive solutions include [SMOOTH TECHNOLOGY](#), [MTConnect®](#), [Mazak SMOOTH Link](#) and the [Mazak SmartBox](#).

SMOOTH TECHNOLOGY

Spanning the entire part-production landscape, Mazak's SMOOTH TECHNOLOGY platform significantly boosts productivity at every stage of the metal cutting process — from programming and setup to actual metal removal operations to automation to monitoring/ data collection and transfer.

Features and benefits of SMOOTH TECHNOLOGY:

- All-encompassing continuously evolving process-performance technology platform
- Combines advanced capabilities of machine tools and leading-edge CNC processing and software technologies
- Makes machine tools easy to use
- Boosts machining speed and performance accuracy

MTCONNECT

As an open-source, royalty-free manufacturing protocol, MTConnect easily connects devices and systems from different suppliers to capture and share information in a common format such as XML. It then gives manufacturers the means to gather valuable data from machines and automated systems for use in process improvement and increased equipment utilization.

With MTConnect, manufacturers can:

- Gain real-time data sharing throughout a manufacturing facility
- Calculate overall equipment efficiency
- Monitor all equipment from one system
- Reduce production losses
- Identify lean manufacturing strategies

Mazak builds all its machines, including those in the VTC Series, to be MTConnect compliant and offers affordable adapters for existing Mazak machines in the field.

SMOOTH
TECHNOLOGY



MTConnect®



MAZAK SMOOTH LINK

Perfect for both large and small shops, Mazak SMOOTH Link makes it possible to sync machine tools with mobile devices to monitor and manage status at any time from a smartphone, tablet or laptop computer. This digital tool captures real-time information from the control and securely transfers the information to a mobile device via Wi-Fi.

Features and benefits of Mazak SMOOTH Link:

- Machine monitoring gives instant operational status of a machine and the workpiece in production
- Displays tool layouts and data of each tool changer pocket/position for effective tool management
- Programming application screen quickly shows all saved EIA programs and machine's remaining storage capacity
- Simple to set up and does not require Internet access, a server PC or server license



Mazak SMOOTH Link

MAZAK SMARTBOX

Secure the “big data” that comes from connecting machines to the Industrial Internet of Things (IIoT). Mazak SmartBox is a launch platform for easy and highly secure entrance into the IIoT. As a scalable, end-to-end solution, SmartBox connects manufacturing equipment, including machines, software and other devices, to a factory's network and allows the free flow of information to management systems via MTConnect.

Features and benefits of Mazak SmartBox:

- Advanced cyber security protection gives IT departments confidence to digitally integrate manufacturing operations
- Completely open architecture and works with all popular third-party analytical software platforms
- Monitor any machine regardless of make, model or age



EXTERNAL DIMENSIONS – VTC-200C (FOR REFERENCE ONLY)

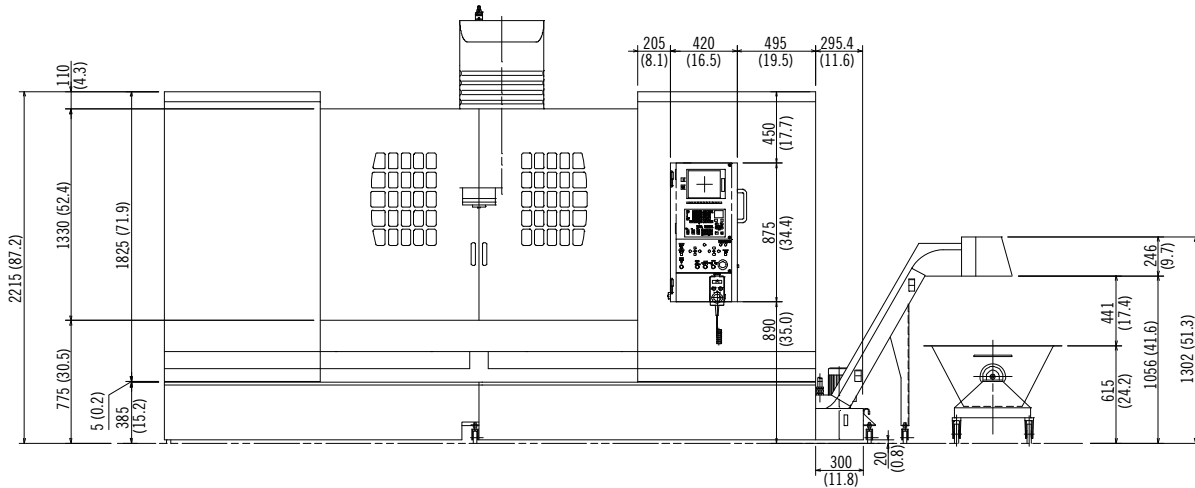
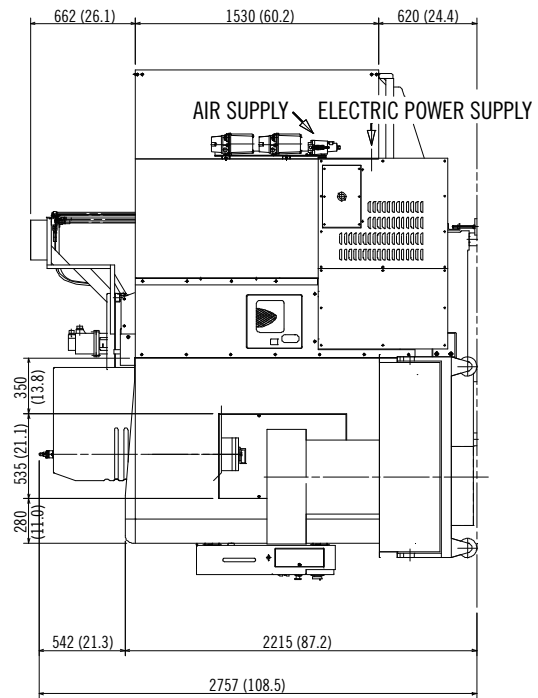
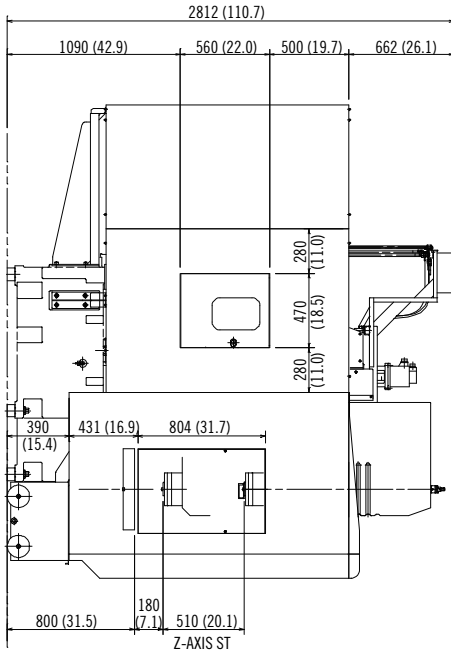

All measurements mm (in).

EXTERNAL DIMENSIONS – VTC-200C (FOR REFERENCE ONLY)

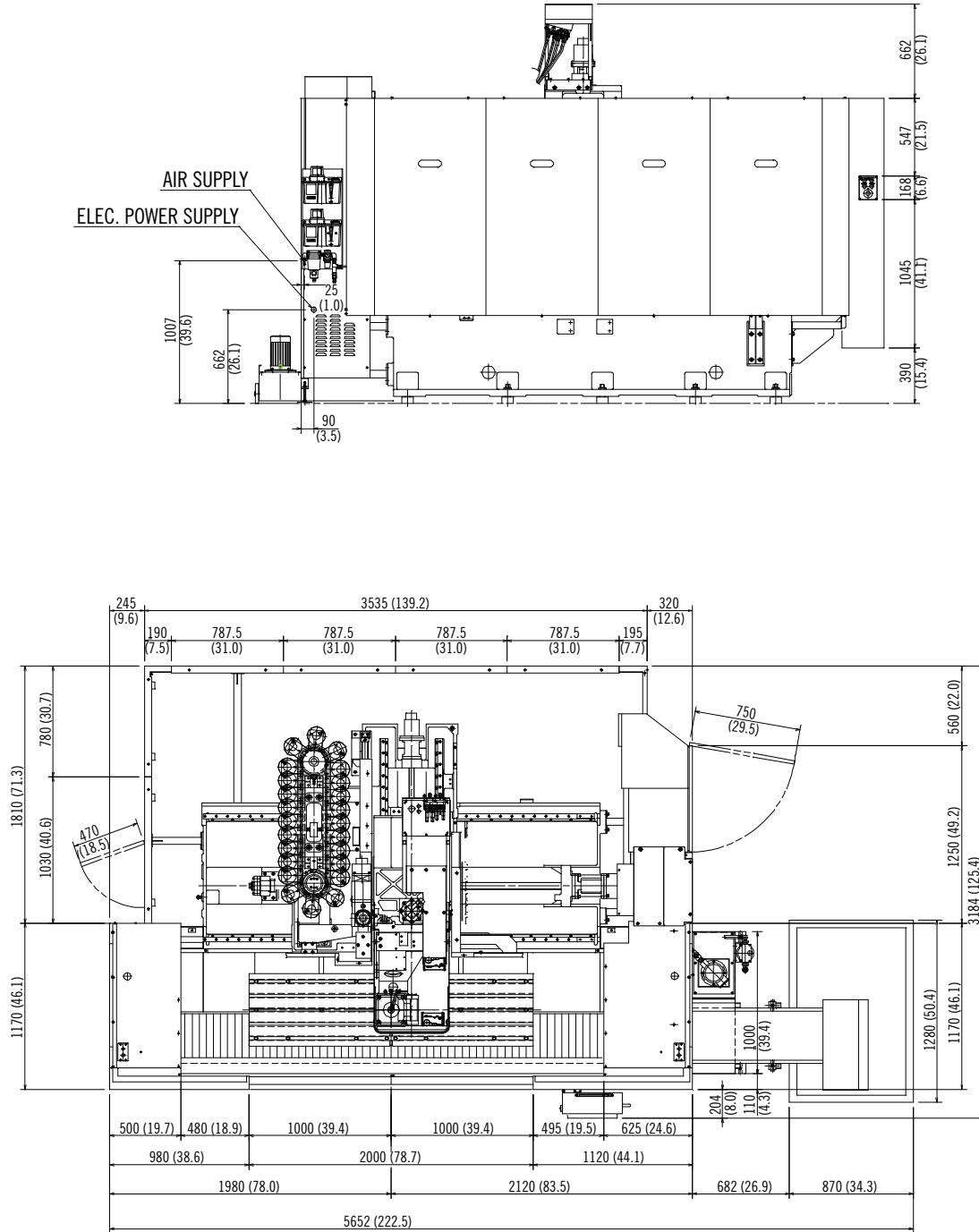

EXTERNAL DIMENSIONS – VTC-200G (FOR REFERENCE ONLY)

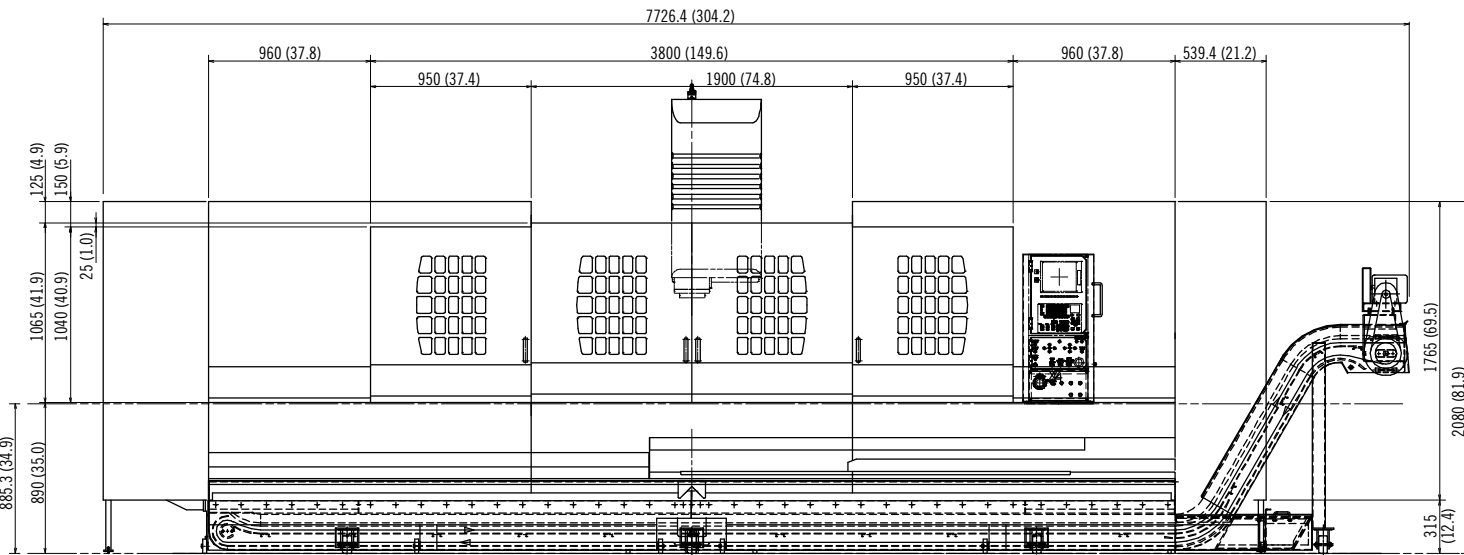
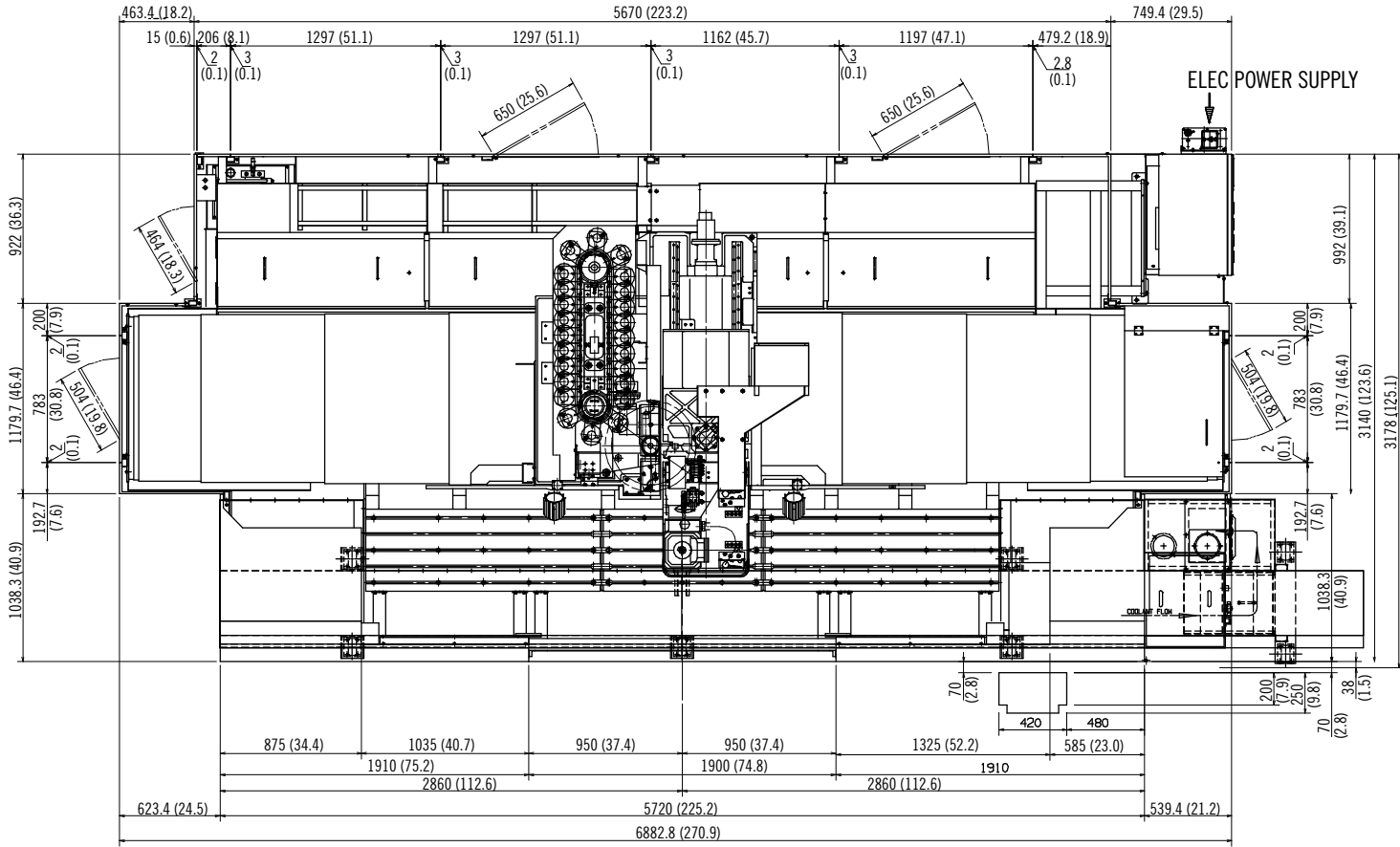

All measurements mm (in).

EXTERNAL DIMENSIONS – VTC-200G (FOR REFERENCE ONLY)

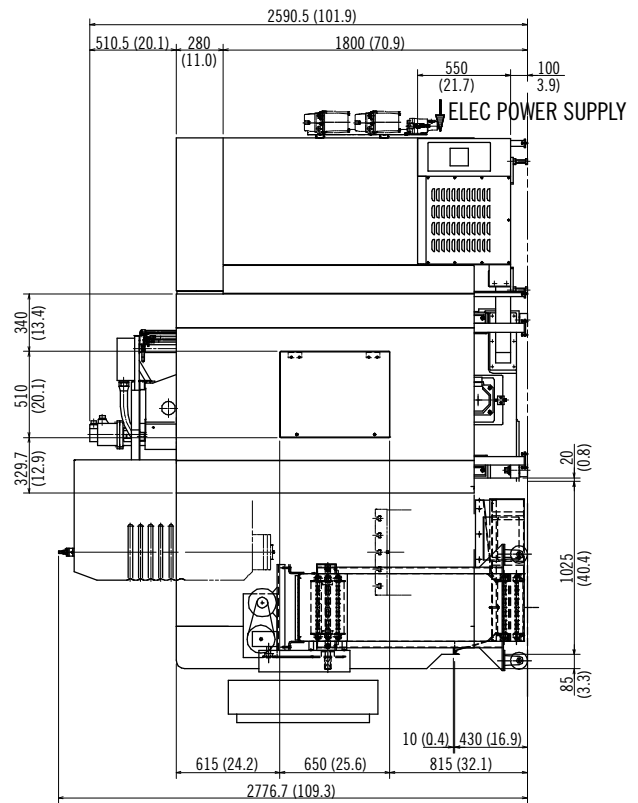
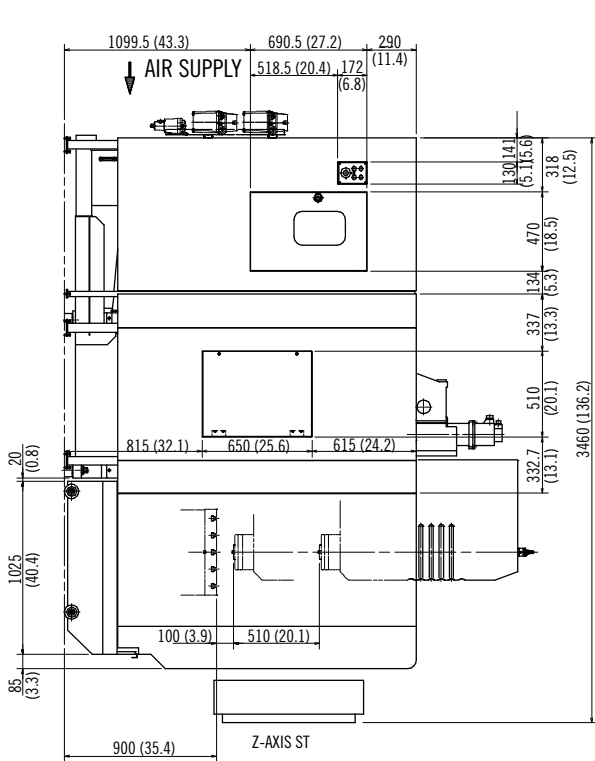
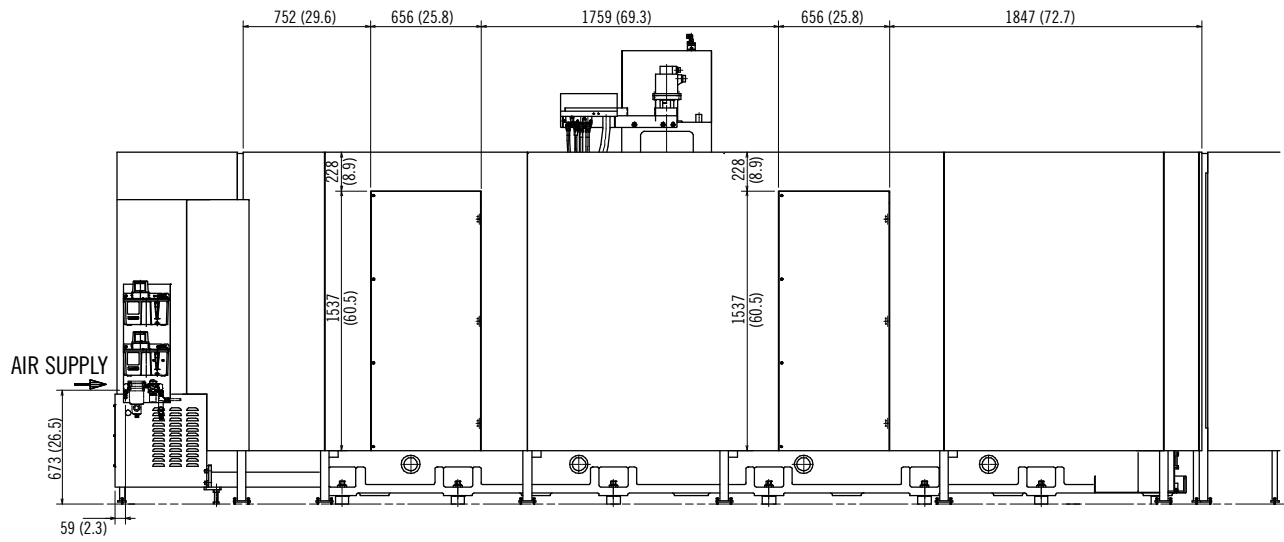

EXTERNAL DIMENSIONS – VTC-250D/50 (FOR REFERENCE ONLY)

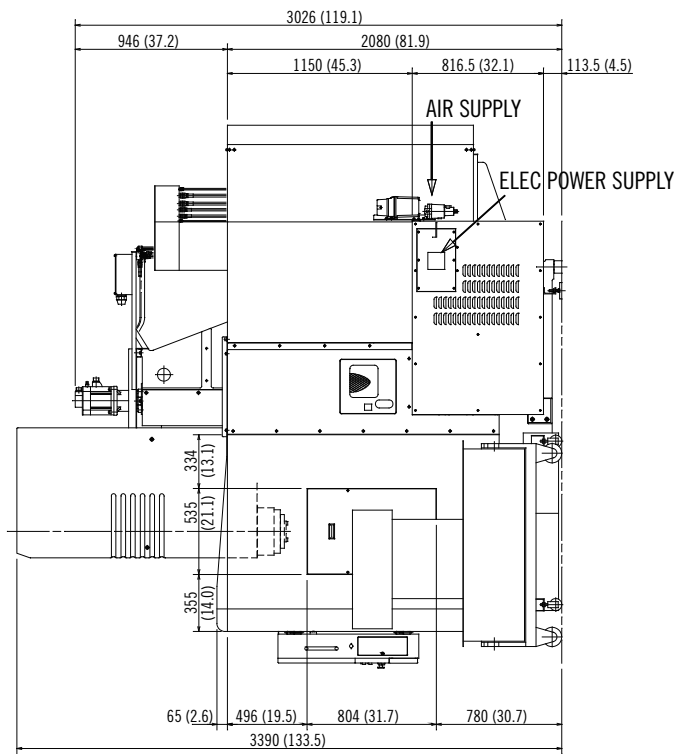
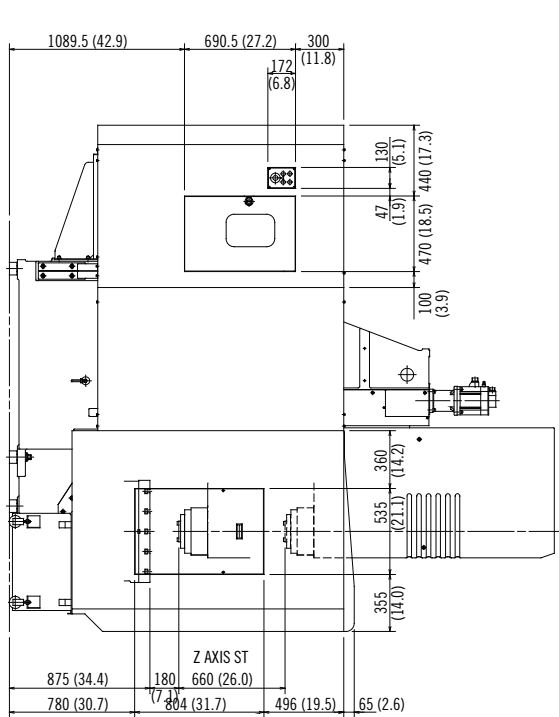
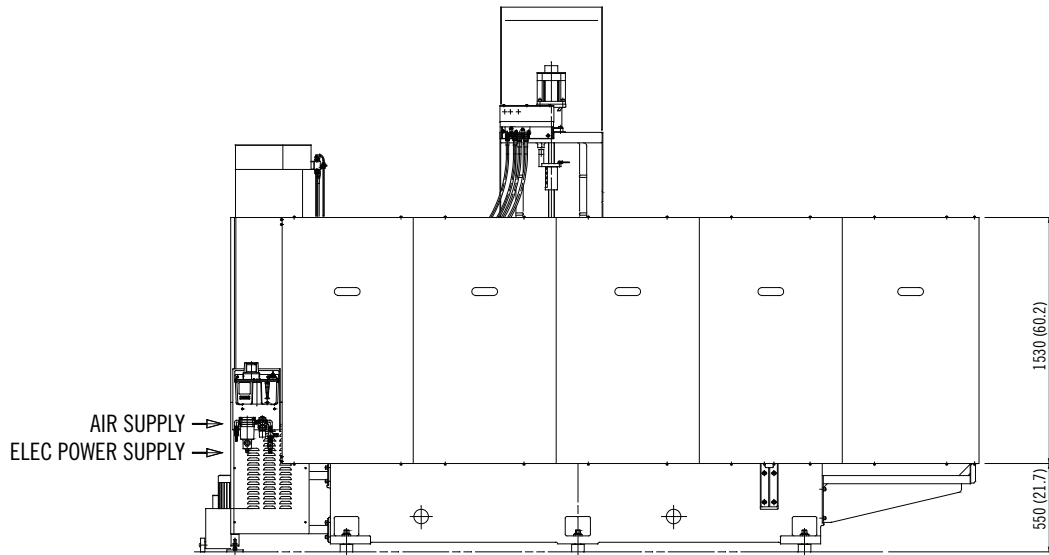

EXTERNAL DIMENSIONS – VTC-300C (FOR REFERENCE ONLY)

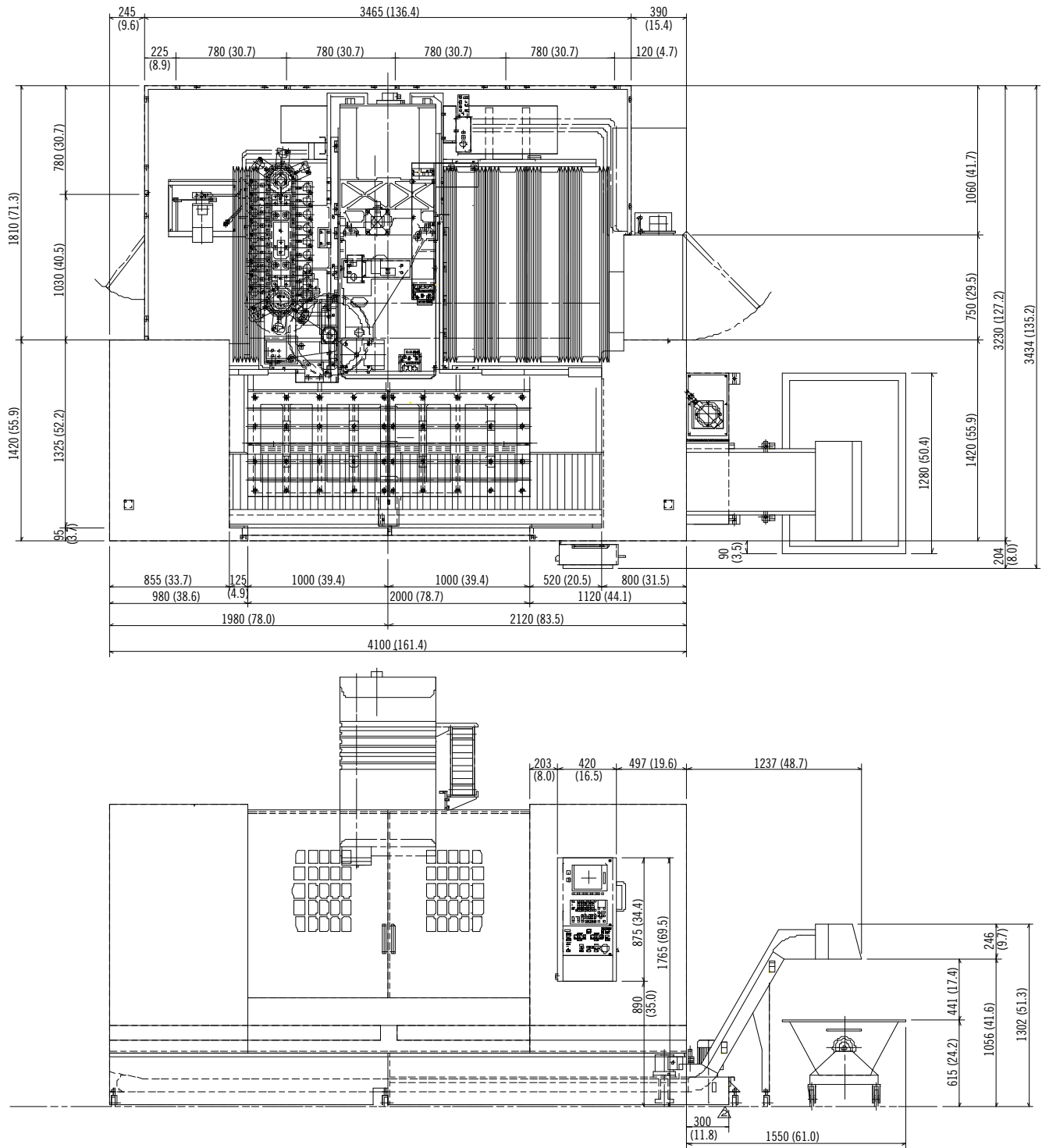

All measurements mm (in).

EXTERNAL DIMENSIONS – VTC-300C (FOR REFERENCE ONLY)

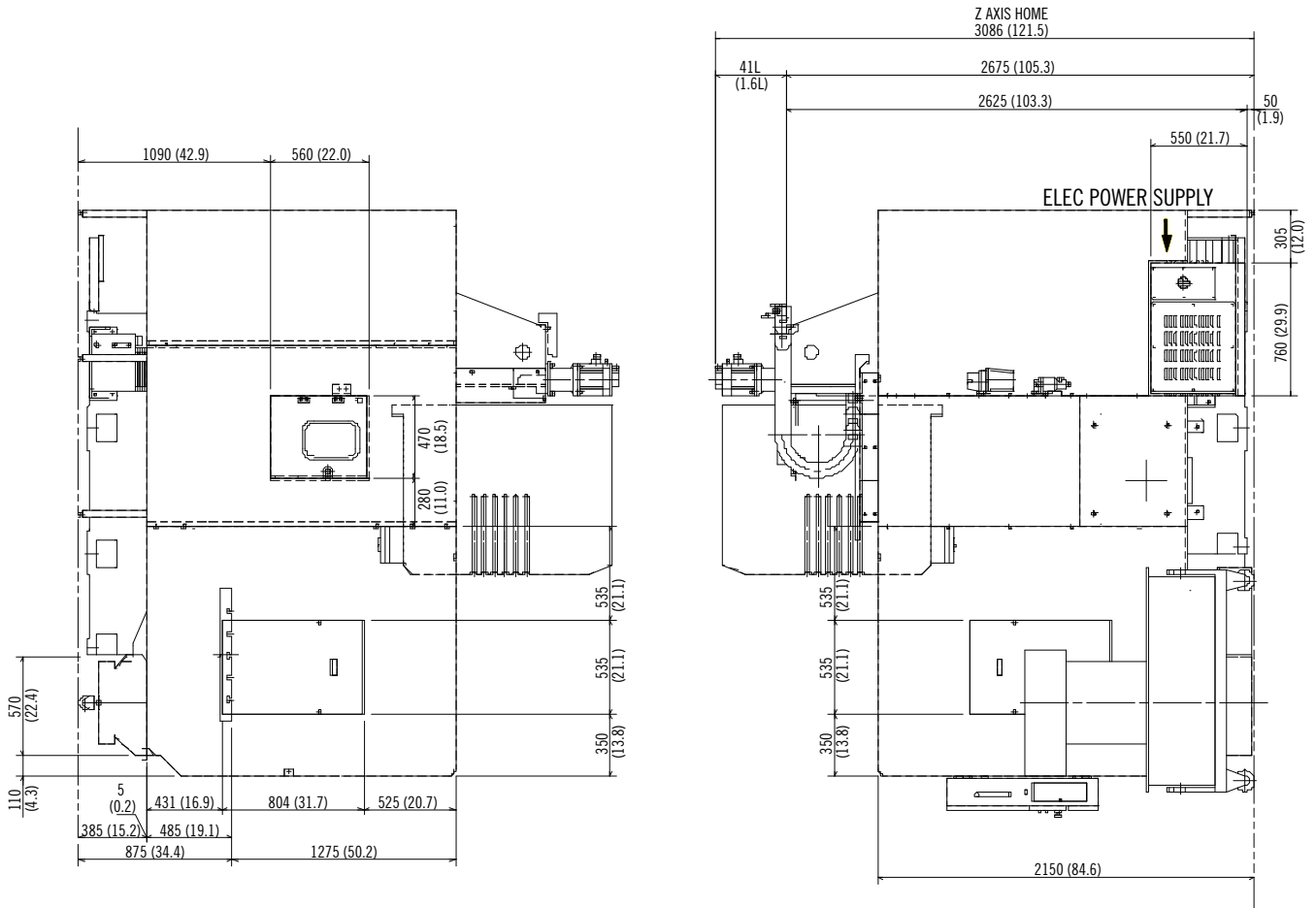
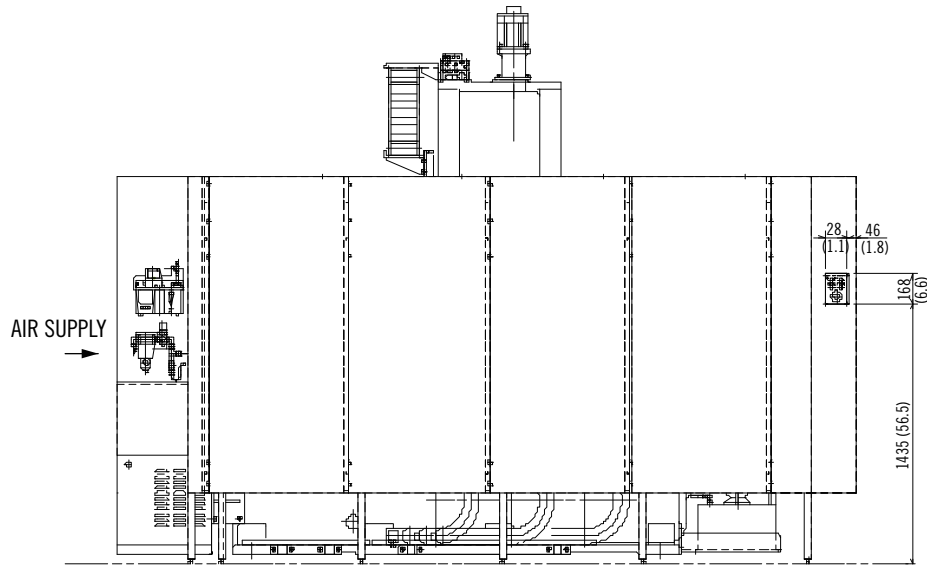

EXTERNAL DIMENSIONS – VTC-800/30 SR (FOR REFERENCE ONLY)

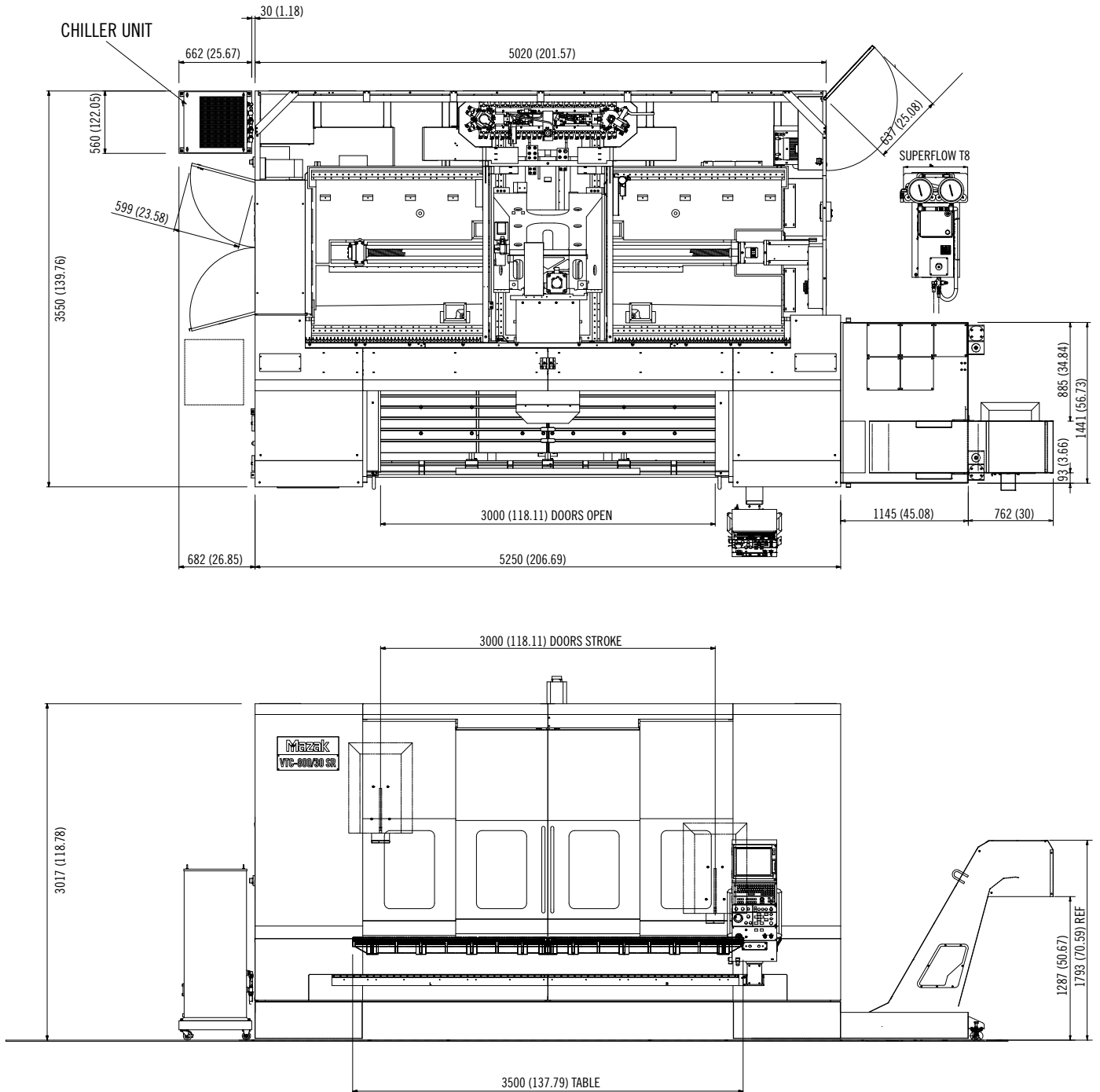

All measurements mm (in).

EXTERNAL DIMENSIONS – VTC-800/30 SR (FOR REFERENCE ONLY)

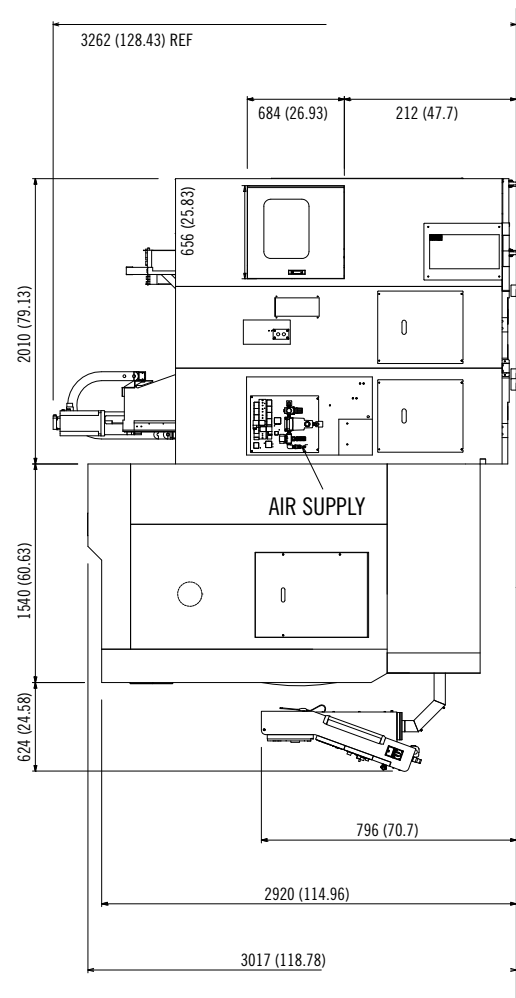
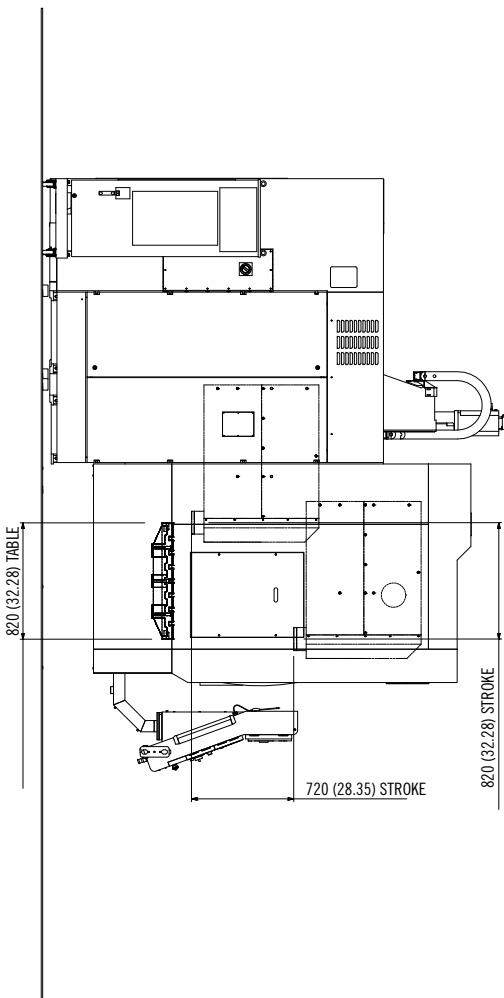
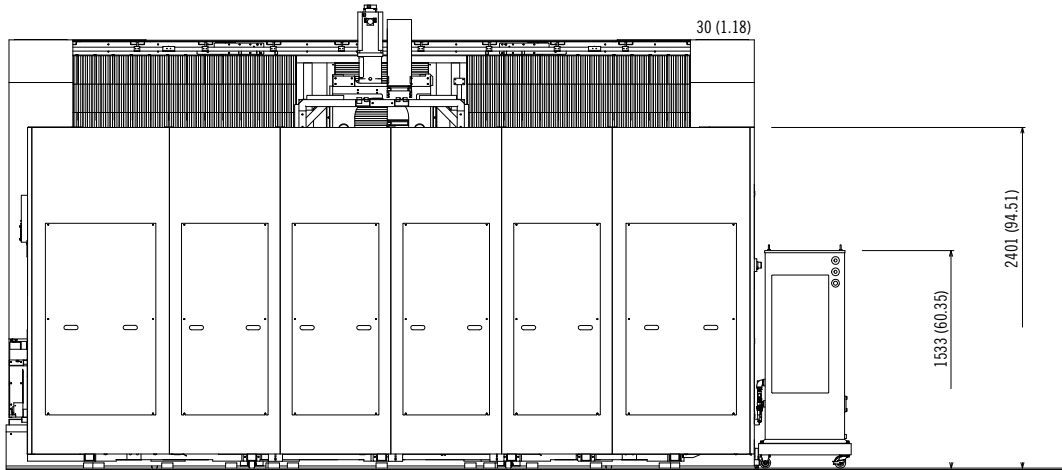

EXTERNAL DIMENSIONS – VTC-805E (FOR REFERENCE ONLY)

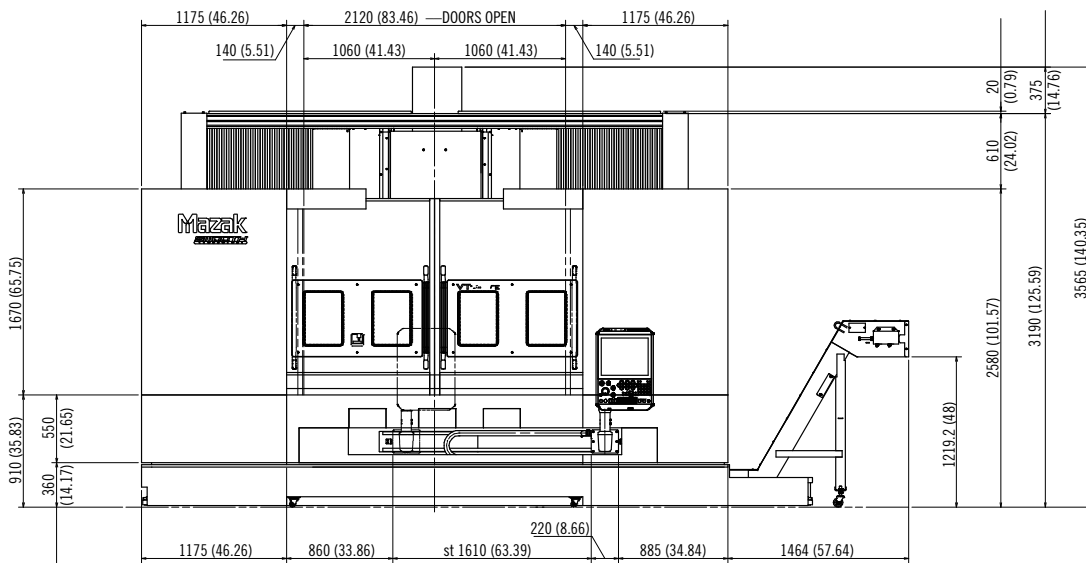
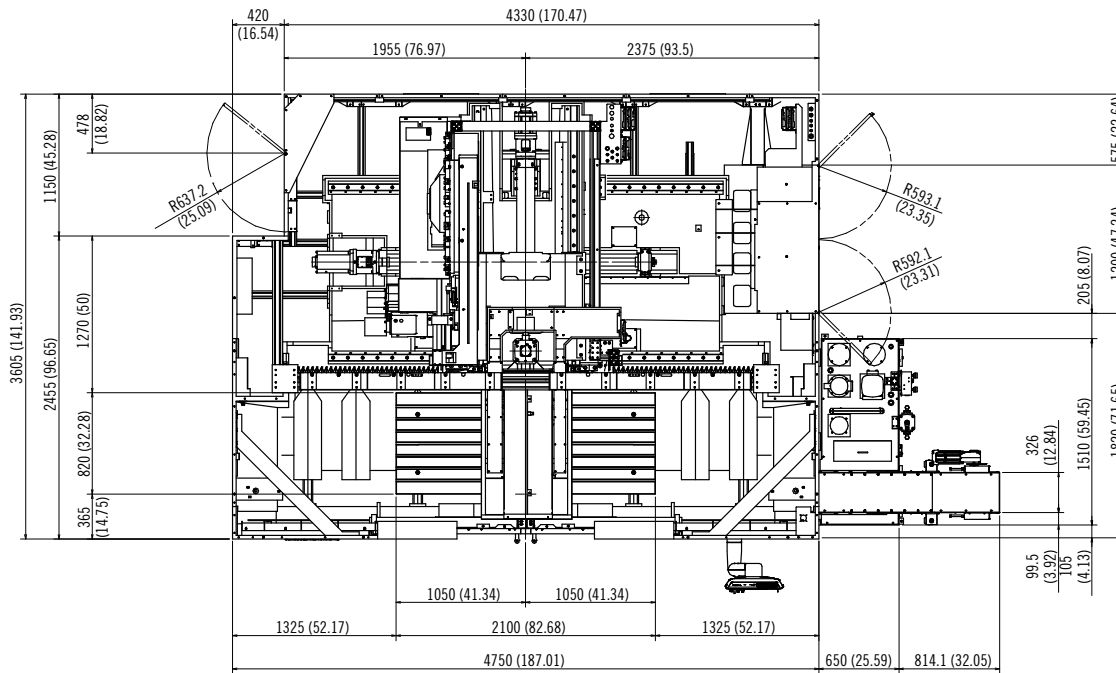

All measurements mm (in).

EXTERNAL DIMENSIONS – VTC-805E (FOR REFERENCE ONLY)

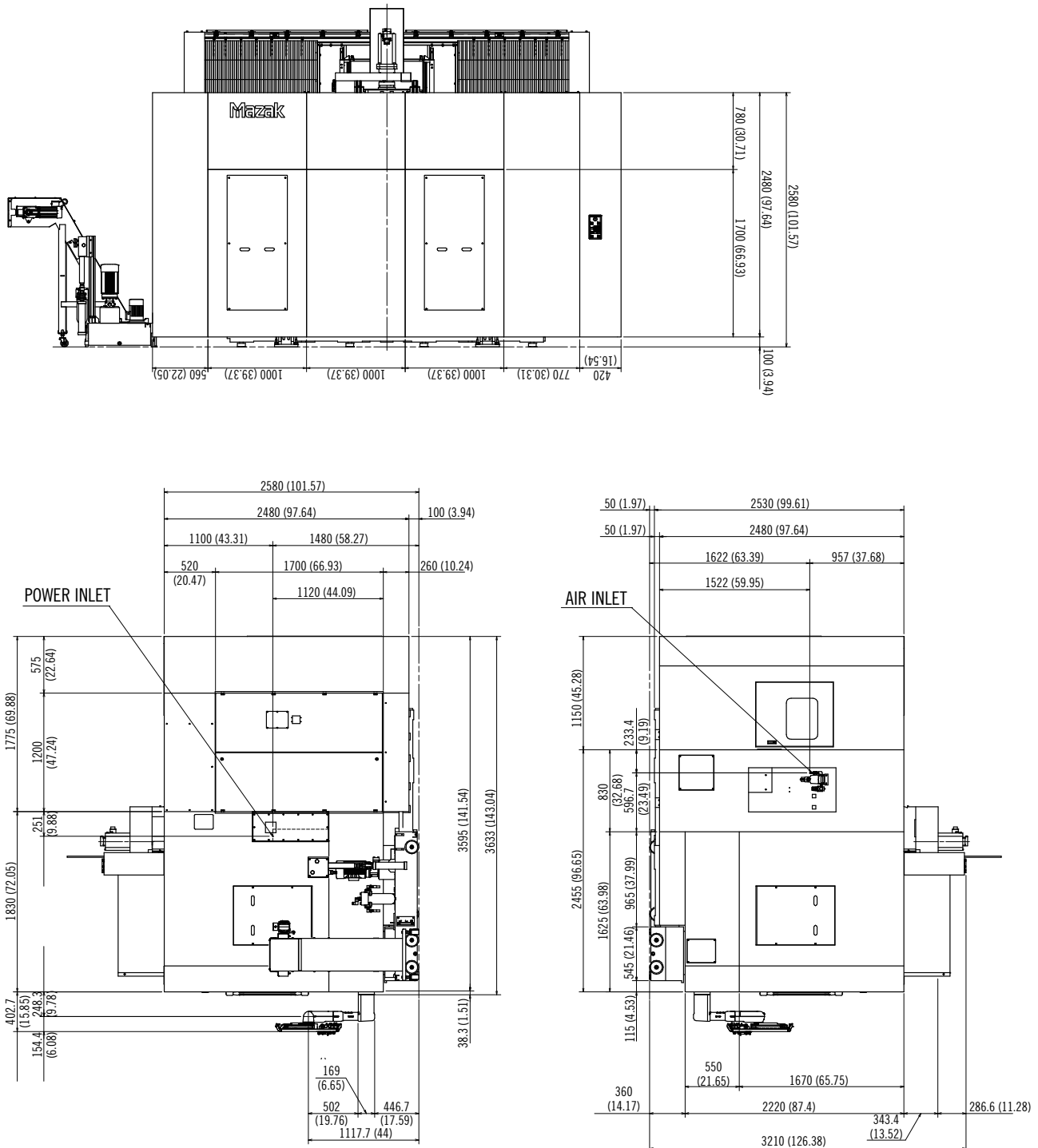

EXTERNAL DIMENSIONS – VTC-805G (FOR REFERENCE ONLY)

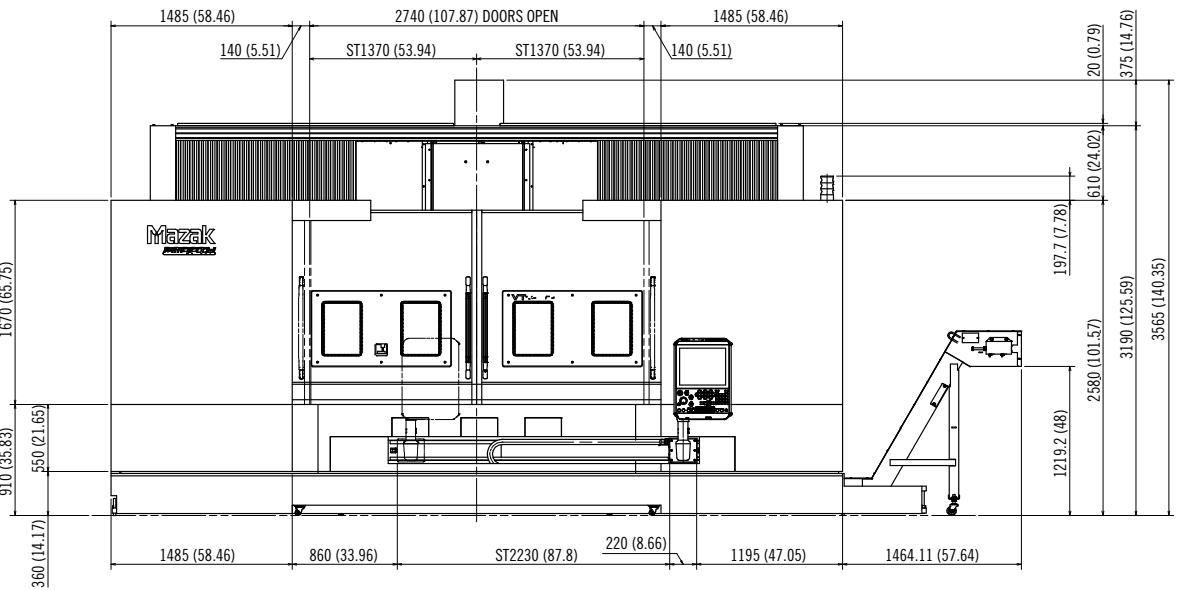
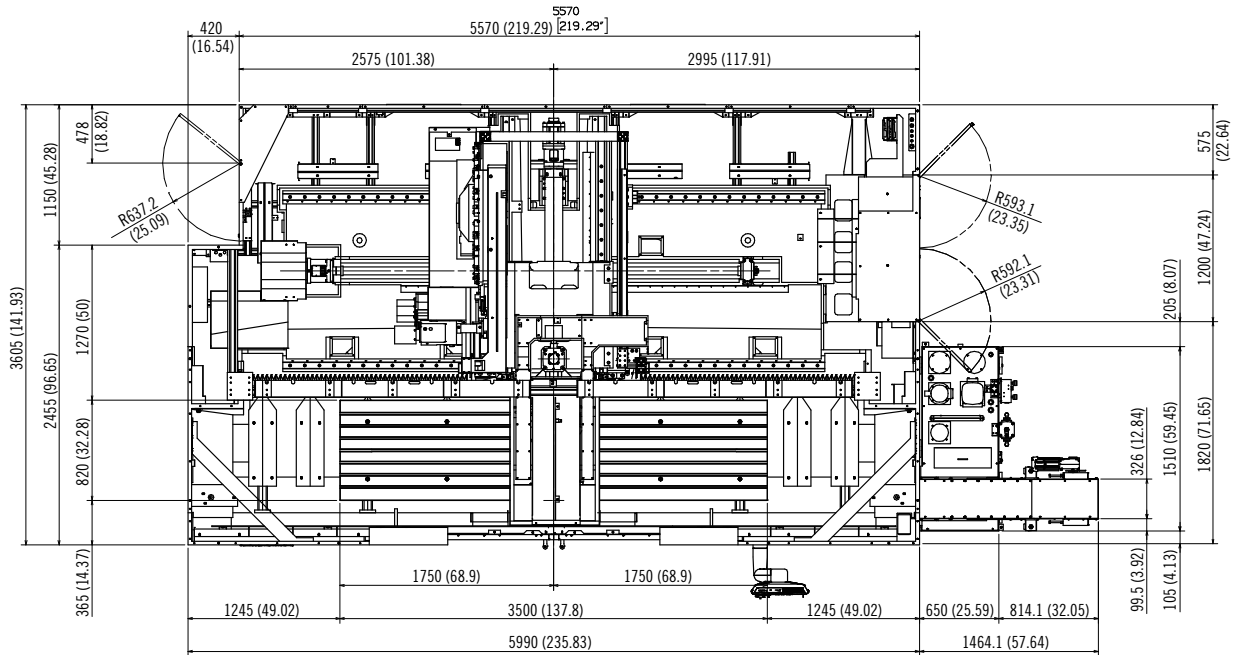

All measurements mm (in).

EXTERNAL DIMENSIONS – VTC-805G (FOR REFERENCE ONLY)

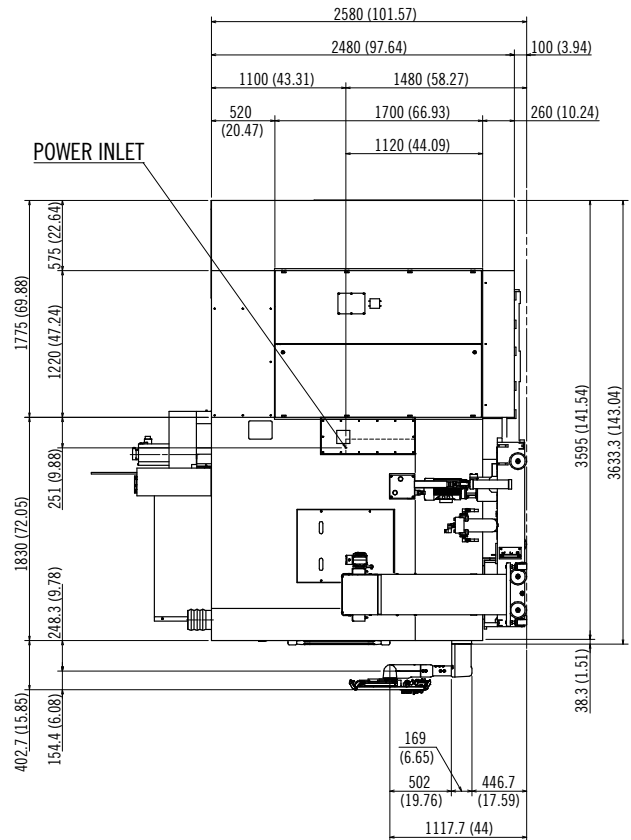
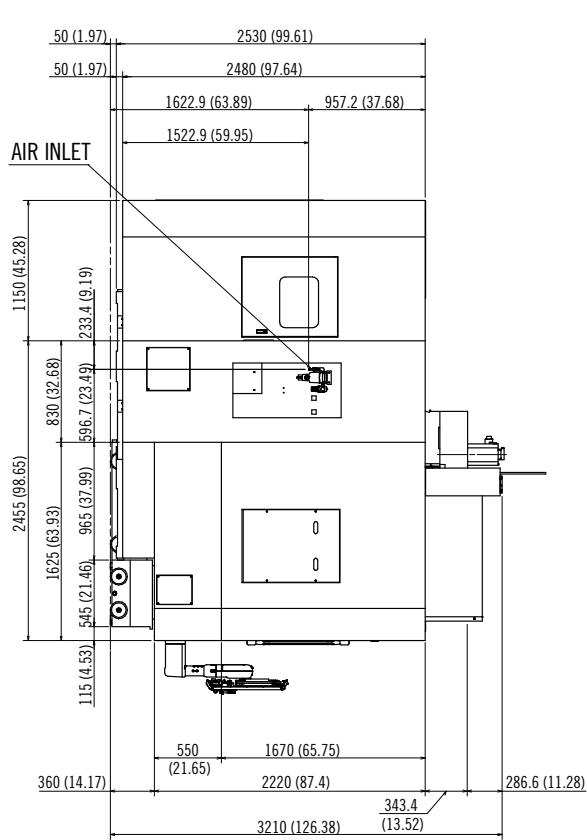
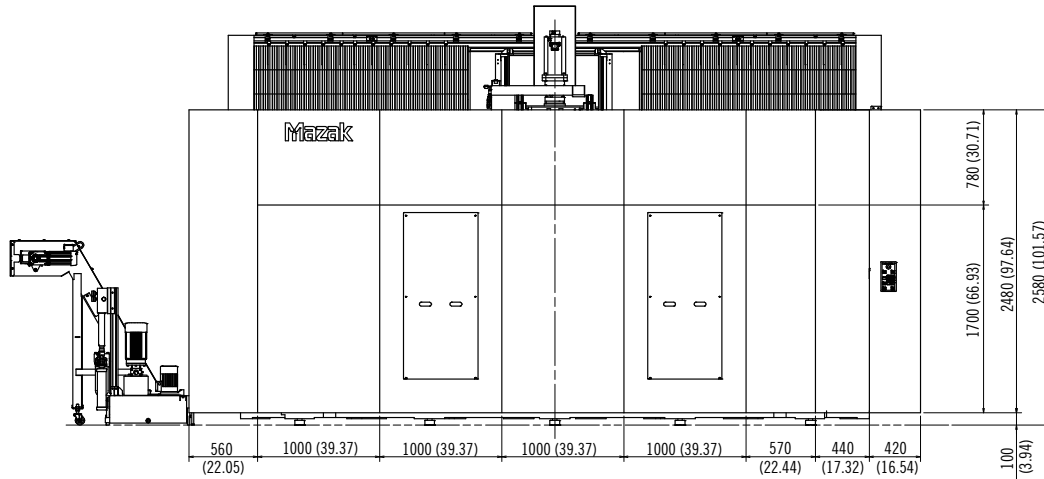

MACHINE SPECIFICATIONS – VTC SERIES

			VTC-200C	VTC-200G	VTC-300C	VTC-800/30 SR
Table	Table size	in (mm)	78.74 x 20.08 (2,000 x 510)	154.33 x 20.08 (3,920 x 510)	78.74 X 30 (2,000 x 760)	137.8 x 32.3 (3,500 x 820)
Spindle	Spindle taper		40	40	40	40
	Maximum speed	rpm	12,000	12,000	12,000	18,000
	Motor output – 5 minutes	hp (kW)	25 (18.5)	25 (18.5)	25 (18.5)	—
	Motor output – 30 minutes	hp (kW)	15 (11)	15 (11)	15 (11)	47 (35)
	Motor output – continuous	hp (kW)	10 (7.5)	10 (7.5)	10 (7.5)	35 (26)
Magazine	Number of tools		24 std, 48 opt	24 std, 48 opt	24 std, 48 opt	30 std, 48 opt
Feed axes	X-axis travel	in (mm)	65.35 (1,660)	144.09 (3,660)	65.35 (1,660)	118 (3,000)
	Y-axis travel	in (mm)	20.08 (510)	20.08 (510)	30.00 (760)	31.5 (800)
	Z-axis travel	in (mm)	20.08 (510)	20.08 (510)	25.6 (660)	28.3 (720)

			VTC-250D/50	VTC-805E	VTC-805G
Table	Pallet size	in (mm)	87.7 x 25 (2,100 x 635)	82.7 x 32.3 (2,100 x 820)	137.8 x 32.3 (3,500 x 820)
Spindle	Spindle taper		50	50	50
	Maximum speed	rpm	6,000 (10,000 option)	6,000 (10,000 option)	6,000 (10,000 option)
	Motor output – 30 minutes	hp (kW)	30 (22)	30 (22)	30 (22)
	Motor output – continuous	hp (kW)	25 (18.5)	25 (18.5)	25 (18.5)
Magazine	Number of tools		24	40	40
Feed axes	X-axis travel	in (mm)	69.3 (1,760)	69.3 (1,760)	118 (3,000)
	Y-axis travel	in (mm)	25 (635)	32.3 (820)	32.3 (820)
	Z-axis travel	in (mm)	25.6 (660)	28.3 (720)	28.3 (720)

HIGH ACCURACY

Mazak's rigid machine base structure, advanced spindle/motor design and MAZATROL CNC submicron machine movement give VTC Series machines extremely high part accuracy and surface finish capabilities. And, as with all the machines built at the Mazak iSMART Factory in Florence, Kentucky, Mazak closely monitors the manufacture and assembly of each and every VTC Series machine to guarantee their consistent precision and performance.

To further ensure the highest precision possible over extended hours of operation, Active Vibration Control and Thermal Shield intelligent machine functions minimize detrimental vibration and heat when machining.

ACTIVE VIBRATION CONTROL

Axis acceleration/deceleration can cause machine vibration. Mazak's Active Vibration Control function effectively reduces vibration for high accuracy positioning in all axes and shorter machining cycle times. It also curbs the effects such vibration has on the cutting tool for longer tool life and exceptional part surface finishes.

INTELLIGENT THERMAL SHIELD

Mazak designs its machine units to generate the least amount of heat possible during operation to minimize displacement. But when ambient shop temperatures fluctuate, the Thermal Shield function automatically compensates via exhaust ducts that channel generated heat out and away from the machine and any machines adjacent to it.

MAZAK iSMART FACTORY

The Mazak iSMART Factory encompasses the complete digital integration of the factory with state-of-the-art manufacturing equipment, automation and advanced manufacturing practices. It hinges on the free flow and sharing of data in terms of process control and operation monitoring to ensure the highest quality standards and the utmost production consistency from one machine to the next.



SPINDLE AND UNIT REBUILD

Spindle rebuild

[Mazak's spindle exchange and rebuild program](#) provides the option to purchase a brand new spindle, have an existing spindle repaired or acquire a Mazak rebuilt spindle.

Benefits of Mazak's spindle and unit rebuild service include:

- More than 900 different spindle variations for all types of turning centers, vertical and horizontal machining centers as well as Multi-Tasking machines.
- Over 300 available rebuilt spindles for a cost-effective spindle solution delivered in as little as two or three days.
- Spindle repairs are processed in a clean room environment and overseen by quality control teams with ISO: 9001:2008 certification.
- Spindle repairs/rebuilds occur within five days of receipt and include 12 hours of test stand runoff.
- A seven-month parts and labor warranty on rebuilt spindles with Mazak installation.
- Free technical support regarding replacement options and processes.



SPINDLE REPAIR



BEFORE



AFTER

ENVIRONMENTALLY FRIENDLY

ENVIRONMENTAL CONSIDERATIONS

The environment and our impact on our natural surroundings have always been important concerns of Mazak. This is shown by the fact that all factories where Mazak machine tools are produced are ISO 14001 certified, an international standard confirming that the operation of our production facilities do not adversely affect air, water or land.

The VTC Series utilizes a high efficiency lubrication system that has reduced oil consumption more than 90% when compared to comparable systems. High efficiency LED work lights are used for illumination of the machining area. These lights and the optional chip conveyor are automatically shut off after a predetermined period for lower power consumption when the machine is in the stand-by state.

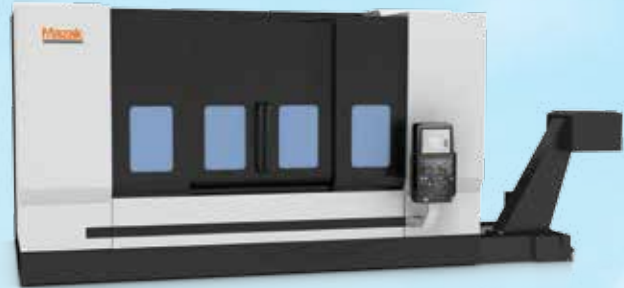

VTC-800/30 SR



Power Consumption Display (Optional)

The electrical power meter displays the machine's accumulated electrical power consumption.

Personnel Sensor

The work lights and CNC display are automatically shut off after a predetermined time period for lower power consumption when the operator is not near the machine. When the personnel sensor has detected that the operator has returned to the machine, these lights are automatically turned on.

Chip Conveyor/Automatic Power Off (Optional)

The chip conveyor is automatically shut off after a predetermined time period for lower power consumption when the machine is in the stand-by state.

MAZAK TECHNOLOGY + TECHNICAL CENTERS

MAZAK TECHNOLOGY AND TECHNICAL CENTERS

As a key component of Mazak's comprehensive customer support, its network of eight Technology Centers and a Technical Center strategically located across North America put component machining demonstrations, experienced applications engineers and training in close proximity to customers. These centers also provide a channel for customer input to Mazak manufacturing for the development of new machine tool technology.

Technology and Technical Centers offer advanced application support, education and training, new technology and manufacturing systems along with on-site training and technology seminars.

[Click here for more information on Mazak Technology Centers.](#)

Advanced application support

- Expert applications engineers help customers optimize part-production processes and create effective manufacturing solutions
- Mazak-certified cutting tool, workholding and automation partners collaborate to develop optimized turnkey manufacturing solutions
- Test cuts of customer parts run on the latest, most advanced machine tools
- Secure applications development and complete design privacy of each customer's individual manufacturing system

Education and training

- Education, training and seminar events in cooperation with Mazak technology partners
- Free access to the most advanced machine tools
- Industry-focused education



New technology and manufacturing systems

- The latest, most advanced manufacturing systems that can optimize the processing of industry-specific components
- Productivity experts help customers select the best new machine tool technology for their particular businesses

On-Site Training and Technology Seminars

- Hands-on applications and operator development courses
- Technical seminars held in conjunction with our Value Inspired Partners (VIPs)
- Regularly scheduled market-focused events that provide valuable industry insight



NATIONAL TECHNOLOGY CENTER

8025 Production Drive
 Florence, Kentucky 41042
 (800) 331-9151



MIDWEST TECHNOLOGY CENTER

300 East Commerce Drive
 Schaumburg, Illinois 60173
 (847) 885-8311



SOUTHWEST TECHNOLOGY CENTER

10950 Greenbend Blvd.
 Houston, Texas 77067
 (281) 931-7770



SOUTHEAST TECHNOLOGY CENTER

1075 Northbrook Parkway
 Suwanee, Georgia 30024
 (678) 985-4800



WESTERN TECHNOLOGY CENTER

1333 West 190th Street
 Gardena, California 90248
 (310) 327-7172



NORTHEAST TECHNOLOGY CENTER

700 Old County Circle
 Windsor Locks, Connecticut 06096
 (860) 292-4400



DALLAS TECHNICAL CENTER

935 South Kimball, Suite 151,
 Southlake, Texas 76092
 (817) 329-6290



CANADA TECHNOLOGY CENTRE

50 Commerce Court
 Cambridge, Ontario N3C 4P7
 (519) 658-2021



MEXICO TECHNOLOGY CENTER

Spectrum 100 Parque Industrial Finsa
 Apodaca Nuevo León 66600
 +52-818-221-0910

[Click here for more information on Mazak Technology Centers.](#)

FINANCING

MAZAK CREDIT GROUP

As a wholly owned subsidiary of Mazak Corporation, MCC Credit Group is the preferred one-stop choice for manufacturers throughout the United States and Canada who want fast, hassle-free, low-cost financing on a VTC Series machine or any other piece of Mazak equipment. With a complete knowledge of Mazak's product portfolio, MCC Credit Group provides factory terms that can work to customer advantages. Plus, its direct access to machine specifications, delivery schedules and installation dates eliminates any additional paperwork or a delay in the approval or shipment process.

Advantages of working with MCC Credit Group:

- Approval of up to \$350,000 with a simple online credit application (subject to credit approval)
- Quick turnarounds on highly competitive leases and loans with no blanket liens
- Waive security deposits
- Apply machine deposits directly toward advanced rents, fees or monthly rental payments
- Offer three to five years financing on all Mazak equipment
- Preserve bank credit lines for working capital and your company's growth
- Structure true leases for off-balance sheet accounting treatment and maximum cash flow

[Click here for more information on financing options.](#)



RESOURCES AND LINKS

NORTH AMERICAN SERVICE

North American Customer Service Manager

Greg Westrick
859-342-1892
gwestrick@mazakcorp.com

Assistant North American Service Manager

Hiroshi Ito
859-342-1466
hito@mazakcorp.com

North American Parts Manager

Steve Trammel
859-342-1790
strammel@mazakcorp.com

Parts Order Entry

Toni Abdon
888-462-9251
pparts@mazakcorp.com

Training Supervisor

Roy Gentry
859-342-1854
rgentry@mazakcorp.com

REGIONAL LOCATIONS

Atlanta

Steve Carbonneau
678-985-4800
800-505-1964
scarbonneau@mazakcorp.com

Chicago

Gary Summers
847-885-8311
800-677-8311
gsummers@mazakcorp.com

Florence, Kentucky

Martin Wilber
859-342-1561
mwilber@mazakcorp.com

Hartford

Kurt Petitti
860-292-4400
800-436-8900
kpetitti@mazakcorp.com

Houston

Jim Jackson
281-931-7770
jjackson@mazakcorp.com

Los Angeles

Carlos Santos
310-327-7172
800-511-8927
csantos@mazakcorp.com

Canada

Michael Cummings
519-230-3233
800-668-5449
mcummings@mazakcorp.com

Mexico

Gustavo Alarcon
011 52 818 221 0910
galarcon@mazakcorp.com

AFTER HOURS SERVICE

800-231-1456

AFTER HOURS PART SUPPORT

[Click here to register for after hours parts support.](#)

Mazak

www.MazakUSA.com

MAZAK CORPORATION
NORTH AMERICAN MANUFACTURING HEADQUARTERS
8025 Production Drive, Florence, KY 41042
Tel: (859) 342-1700 Fax: (859) 342-1865

06_17_SER_VTC_B

VTC SERIES