



Asset-Trade

Assessment & Sale of Used Assets

Ref. Nr.: 815-04281000

Overview and Technical Data:

WAFIOS - FM8 Federwindemaschinen

WAFIOS

WAFIOS 

Baujahr: Jan. 1955



Asset-Trade

Assessment & Sale of Used Assets



Description:

Gebrauchte WAFIOS FM 8 Federwindemaschinen

2x Maschines verfügbar + 1 angetriebene Haspel

Optional 2x Draht Messgeräte verfügbar

Technical Data

- Drahtdurchmesser 0,2-0,8 mm
- Federdurchmesser 1- 20 mm
- Max Leistung 300 Stück/min
- Einzugslänge: 900 mm
- Anschluss: 380 V

Abmessungen LxWxH 750x425x1280mm



Technical Data:

Technical Data:

Steuerung: NC

Dimensions and Weight:

Höhe: 1.280 mm

Länge: 750 mm

Breite: 425 mm

Gewicht: 350 kg

Buyer Information:

Zustand: Normale Beanspruchung

Verfügbarkeit: Sofort

Verkauft als:

FOR/FOT (Free On Rail/Free On Truck)

MwSt.: 19 %

Standort: Deutschland



Images:



3







9



11



10



12

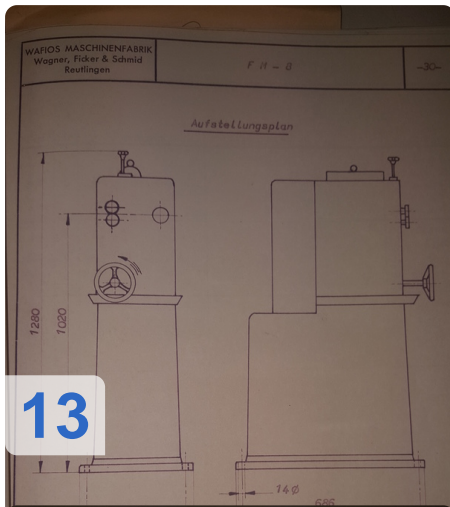

13

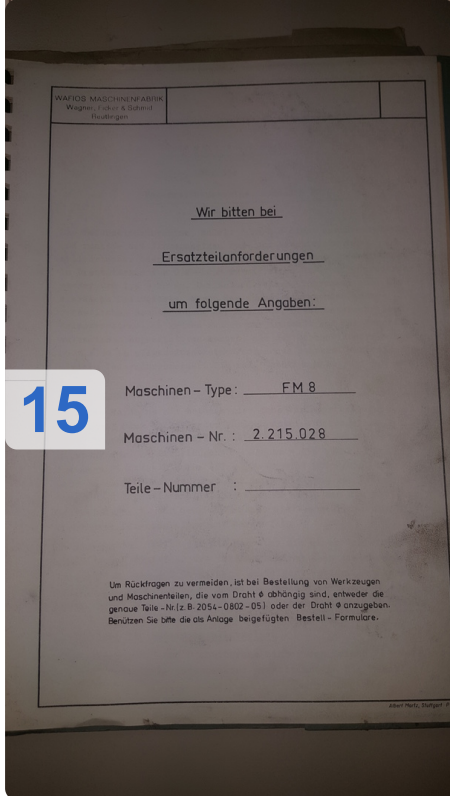

15

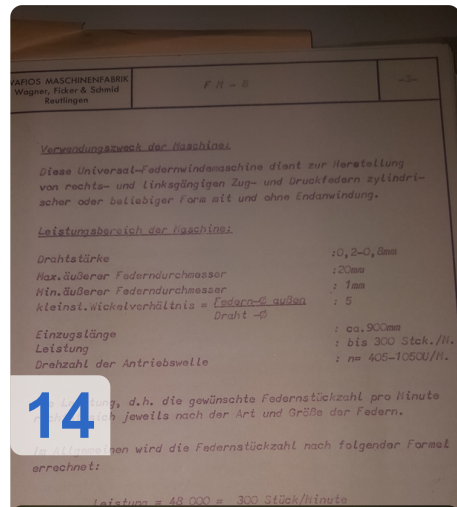

14

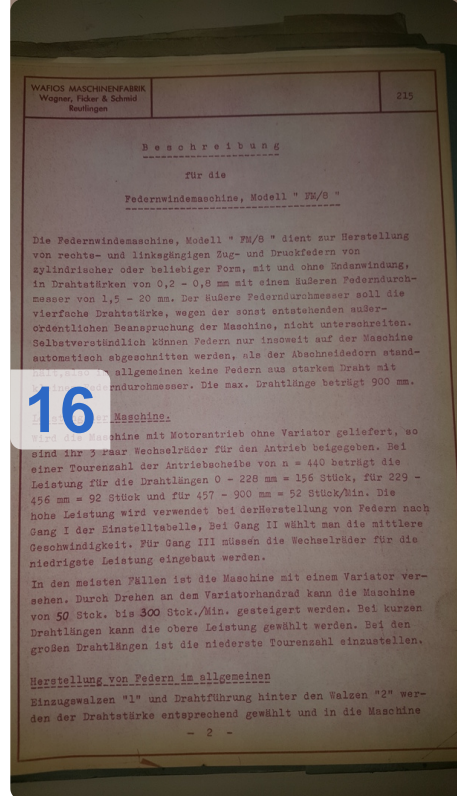

16

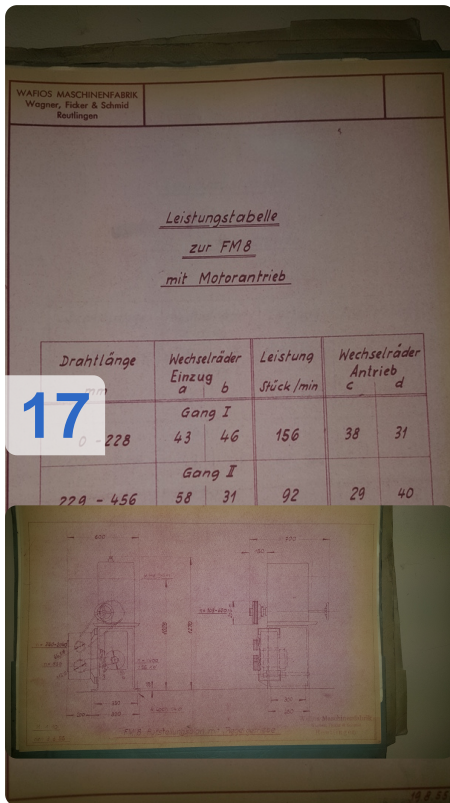

17

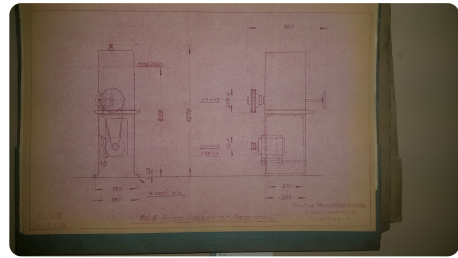

18

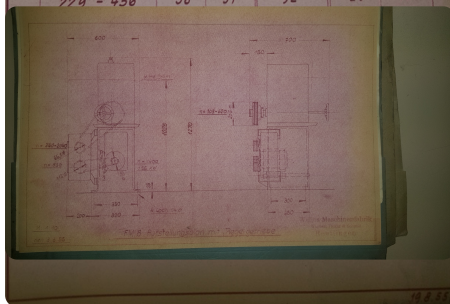

19



21



Asset-Trade

Assessment & Sale of Used Assets



Asset-Trade

**Bewertung & Vermarktung von
Industrieanlagen weltweit**

Am Sonnenhof 16

47800 Krefeld

Deutschland

Tel.: +49 2151 32500 33